

V246 Series 2-Way Pressure-Actuated Water-Regulating Valves for High-Pressure Refrigerants

Description

The V246 Series 2-Way Pressure-Actuated Water-Regulating Valves for High-Pressure Refrigerants come in two types of control action: direct acting or reverse acting. V246 valves regulate water flow to control refrigerant head pressure in systems with water-cooled condensers.

The V246 Series Valves are available in 3/8 in. through 1-1/2 in. sizes and have a maximum allowable water pressure of 150 psi (10.3 bar). V246 valves have an adjustable opening point in a refrigerant pressure range of 200 to 400 psi (13.8 to 27.6 bar). V246 valves may be used with standard non-corrosive refrigerants.

Maritime models, which have nickel copper (Monel®) internal parts, are available for applications where the media may be corrosive to the internal parts.

Features

- No Close Fitting or Sliding Parts in Water Passages
- Accessible Range Spring
- Take-Apart Construction
- Pressure-Balanced Design
- Corrosion-Resistant Material for Internal Parts

Repair Information

If the V246 Series 2-Way Pressure-Actuated Water-Regulating Valve for High Pressure Refrigerants fails to operate within its specifications, refer to the *V246 Series 2-Way Pressure-Actuated Water-Regulating Valves for High Pressure Refrigerants Product Bulletin (LIT-12011514)* for a list of repair parts available.



V246 Series Valve

Valve Selection

North American Standard Production Models - Range 200 to 400 psi

Product Code Number	Construction	Valve Size and Connection	Element Style	Shipping Weight, lb (kg)
V246GA1-001C	Direct Acting, Commercial	3/8 in. NPT Screw	Style 5	1.8 (0.8)
V246GB1-001C	Direct Acting, Commercial	1/2 in. NPT Screw	Style 5	3.0 (1.4)
V246GC1-001C	Direct Acting, Commercial	3/4 in. NPT Screw	Style 5	3.7 (1.7)
V246GD1-001C	Direct Acting, Commercial	1 in. NPT Screw	Style 5	9.3 (4.2)
V246GE1-001C	Direct Acting, Commercial	1-1/4 in. NPT Screw	Style 5	10 (4.5)
V246GM1-001C	Direct Acting, Commercial	1-1/4 in. Union Sweat	Style 5	10 (4.5)
V246GR1-001C	Direct Acting, Commercial	1-1/2 in. Flange	Style 5	13.6 (6.2)
V246HA1-001C	Direct Acting, Maritime	3/8 in. NPT Screw	Style 5	1.8 (0.8)
V246HB1-001C	Direct Acting, Maritime	1/2 in. NPT Screw	Style 5	3.0 (1.4)
V246HC1-001C	Direct Acting, Maritime	3/4 in. NPT Screw	Style 5	4.3 (2.0)
V246HD1-001C	Direct Acting, Maritime	1 in. NPT Screw	Style 5	9.5 (4.3)
V246HE1-001C	Direct Acting, Maritime	1-1/4 in. NPT Screw	Style 5	10.3 (4.7)
V246HR1-001C	Direct Acting, Maritime	1-1/2 in. ASME Flange	Style 5	13.6 (6.2)
V246QA1-001C	Reverse Acting, Commercial	3/8 in. NPT Screw	Style 5	1.8 (0.8)
V246KA1-001C	Direct Acting, Commercial, Low Flow	3/8 in. NPT Screw	Style 5	1.8 (0.8)
V246QB1-001C	Reverse Acting, Commercial	1/2 in. NPT Screw	Style 5	3.0 (1.4)
V246QC1-001C	Reverse Acting, Commercial	3/4 in. NPT Screw	Style 5	3.7 (1.7)
V246QD1-001C	Reverse Acting, Commercial	1 in. NPT Screw	Style 5	9.3 (4.2)
V246QE1-001C	Reverse Acting, Commercial	1-1/4 in. NPT Screw	Style 5	10 (4.5)
V246QR1-001C	Reverse Acting, Commercial	1-1/2 in. Flange	Style 5	13.6 (6.2)

European Standard Production Models - Range 13.8 to 27.6 bar (Part 1 of 2)

Product Code Number	Construction	Valve Size and Connection	Element Style	Shipping Weight, kg (lb)
V246GA1A001C	Direct Acting, Commercial	3/8 in. BSPP Screw, ISO 228	Style 5	1.86 (4.1)
V246GB1A001C	Direct Acting, Commercial	1/2 in. BSPP Screw, ISO 228	Style 5	1.4 (3.0)
V246GC1A001C	Direct Acting, Commercial	3/4 in. BSPP Screw, ISO 228	Style 5	1.7 (3.7)
V246GD1B001C	Direct Acting, Commercial	1 in. BSPT Screw, ISO 7	Style 5	4.2 (9.3)
V246GE1B001C	Direct Acting, Commercial	1-1/4 in. BSPT Screw, ISO 7	Style 5	4.5 (10)
V246GR1B001C	Direct Acting, Commercial	1-1/2 in. Flange, DIN2533	Style 5	6.2 (13.6)
V246HA1B001C	Direct Acting, Maritime	3/8 in. BSPP Screw, ISO 228	Style 5	1.86 (4.1)
V246HB1B001C	Direct Acting, Maritime	1/2 in. BSPP Screw, ISO 228	Style 5	1.4 (3.0)
V246HC1B001C	Direct Acting, Maritime	3/4 in. BSPP Screw, ISO 228	Style 5	2.0 (4.3)

The performance specifications are nominal and conform to acceptable industry standards. For applications at conditions beyond these specifications, consult the local Johnson Controls office. Johnson Controls, Inc. shall not be liable for damages resulting from misapplication or misuse of its products. © 2010 Johnson Controls, Inc. www.johnsoncontrols.com

V246 Series 2-Way Pressure-Actuated Water-Regulating Valves for High-Pressure Refrigerants (Continued)

European Standard Production Models - Range 13.8 to 27.6 bar (Part 2 of 2)

Product Code Number	Construction	Valve Size and Connection	Element Style	Shipping Weight, kg (lb)
V246HD1B001C	Direct Acting, Maritime	1 in. BSPP Screw, ISO 228	Style 5	4.3 (9.5)
V246HE1B001C	Direct Acting, Maritime	1-1/4 in. BSPP Screw, ISO 228	Style 5	4.7 (10.3)
V246HR1B001C	Direct Acting, Maritime	1-1/2 in. Flange, DIN86021	Style 5	6.2 (13.6)

Valve Sizing Information

Each application is unique and requires specific engineering data to properly size and design a system to fulfill the appropriate requirements. Typically, a valve is replaced with another valve of the same size in a properly sized and engineered system. In North America, contact Johnson Controls/PENN® Refrigeration Application Engineering at 1-800-275-5676 to obtain specific engineering data. In other areas, contact the local Johnson Controls® sales office to obtain specific engineering data.

To make a rough field estimate of the size of valve for an application, find the valve size needed by locating a point on a flow chart that satisfies these requirements:

- water flow required by the condenser (**Flow**)
- refrigerant head pressure rise (**P_{RISE}**)
- available water pressure (**P_{AVAIL}**)

Follow these steps, and use the information obtained to locate a point on one of the flowcharts that satisfies all three steps.

1. Take the water flow required by the condenser (**Flow**) from information provided by the manufacturer of the condensing unit. If the manufacturer's information is unavailable, use the following information to make a rough approximation of water flow in gallons per minute (gpm) [cubic meters per hour (m³/hr)] :

- System Capacity (**Tons of Refrigeration**)
- Outlet Water Temperature (**Temp. _{Outlet}**)
- Inlet Water Temperature (**Temp. _{Inlet}**)

Calculate the flow using the following formula:

$$\text{Flow} = \frac{\text{Tons of Refrigeration} \times 30}{(\text{Temp.}_{\text{Outlet}} - \text{Temp.}_{\text{Inlet}})}$$

Flow Required

Note: If the outlet temperature is unknown, assume it to be 10F° (6C°) above the inlet temperature.

2. Determine refrigerant head pressure rise above the valve opening point (**P_{RISE}**) using Figure and the following steps:

- a. The **Valve Closing Pressure (P_{CLOSE})** is equal to the refrigerant pressure at the highest ambient temperature the refrigeration equipment experiences in the Off cycle. Use a Pressure-Temperature Chart for the refrigerant selected to find this pressure.
- b. To approximate the **Valve Opening Pressure (P_{OPEN})**, add about 10 psi (0.7 bar) to the Valve Closing Pressure.

Note: Add about 20 psi (1.4 bar) for 3/8 in. valves.

$$P_{\text{OPEN}} = P_{\text{CLOSE}} + 10 \text{ psi (0.7 bar)}$$

Valve Opening Pressure

- c. From the Pressure-Temperature Chart for the refrigerant selected, read the **Refrigerant Condensing Pressure (P_{COND})** (operating head pressure) corresponding to the selected condensing temperature.
- d. Subtract the Valve Opening Pressure from the Refrigerant Condensing Pressure. This gives the head pressure rise.

$$P_{\text{RISE}} = P_{\text{COND}} - P_{\text{OPEN}}$$

Refrigerant Head Pressure Rise

3. Determine the available water pressure to the valve (**P_{AVAIL}**) using the following steps. This is the actual water pressure available to force water through the valve.
 - a. Determine the inlet pressure (**P_{IN}**). This is the water pressure from city water mains, pumps, or other sources.
 - b. Pressure drop through condenser (**ΔP_{COND}**) is the difference in water pressure between the condenser inlet and the condenser outlet. Obtain this information from the condenser manufacturer.
 - c. Estimate or calculate the pressure drop through all associated piping (**P_{LOSS}**).
 - d. Subtract the **ΔP_{COND}** and **P_{LOSS}** from **P_{IN}**. The result is **P_{AVAIL}**.

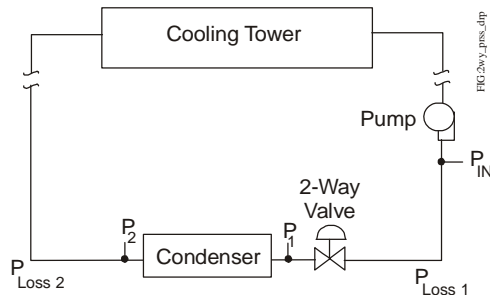

$$\Delta P_{\text{COND}} = P_1 - P_2$$

$$P_{\text{LOSS}} = P_{\text{Loss 1}} + P_{\text{Loss 2}} + \dots$$

$$P_{\text{AVAIL}} = P_{\text{IN}} - (\Delta P_{\text{COND}} + P_{\text{LOSS}})$$

Available Water Pressure

4. Select the proper valve size from the flowcharts by locating a point on a chart that satisfies the flow, the head pressure rise above opening point, and the pressure drop across the valve.

Metric Conversions

Use these equations to convert between U.S. and S.I. units.

- 1 dm³/s = 3.6 m³/h = 15.9 U.S. gal. /min. = 13.2 U.K. gal. /min.
- 1 bar = 100 kPa = 0.1 MPa = 1.02 kg/cm² = 0.987 atm = 14.5 psi

V246 Series 2-Way Pressure-Actuated Water-Regulating Valves for High-Pressure Refrigerants (Continued)

V246 Flowcharts

The maximum recommended differential water pressure across a valve is 60 psi (4.1 bar).

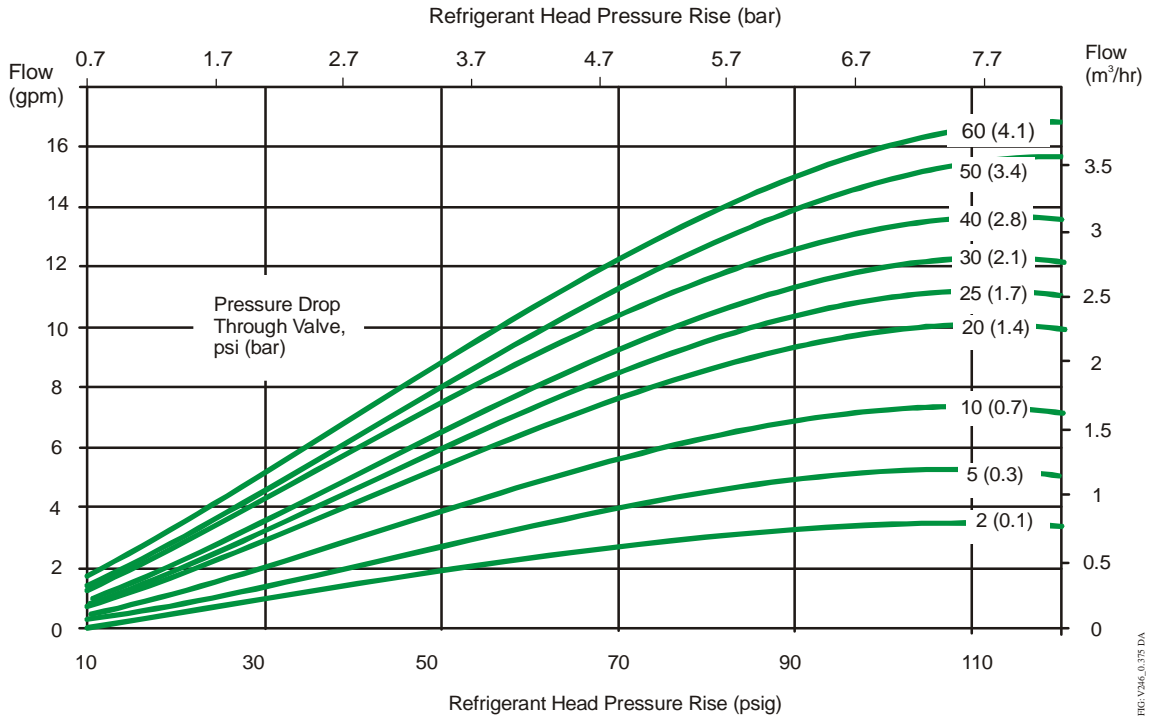

3/8 in. Direct Acting Valve Flowchart

FIG. V246_0_375 DA

V246 Series 2-Way Pressure-Actuated Water-Regulating Valves for High-Pressure Refrigerants (Continued)

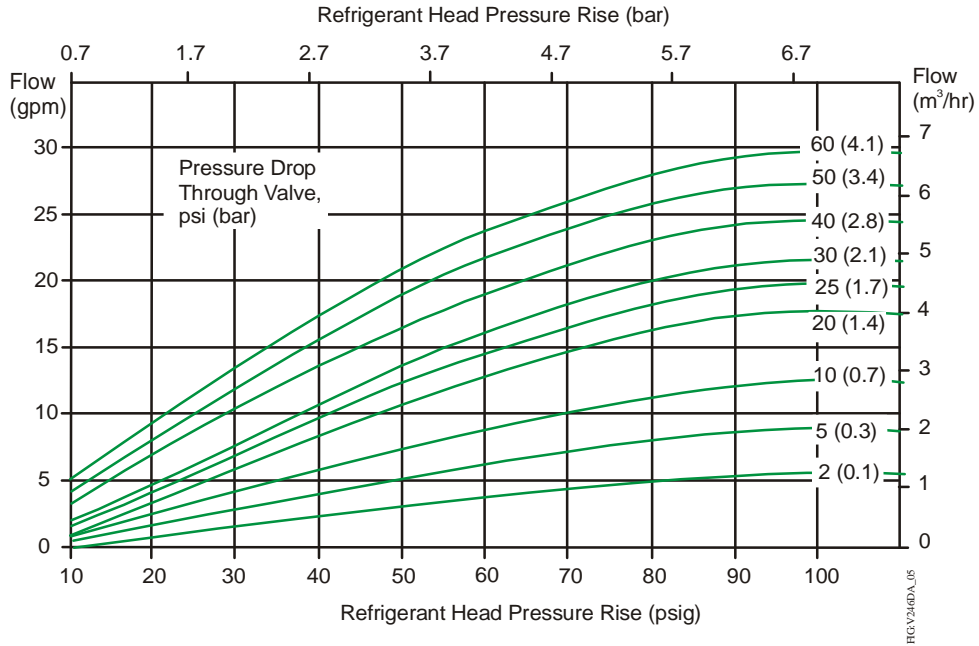

1/2 in. Direct Acting Valve Flowchart

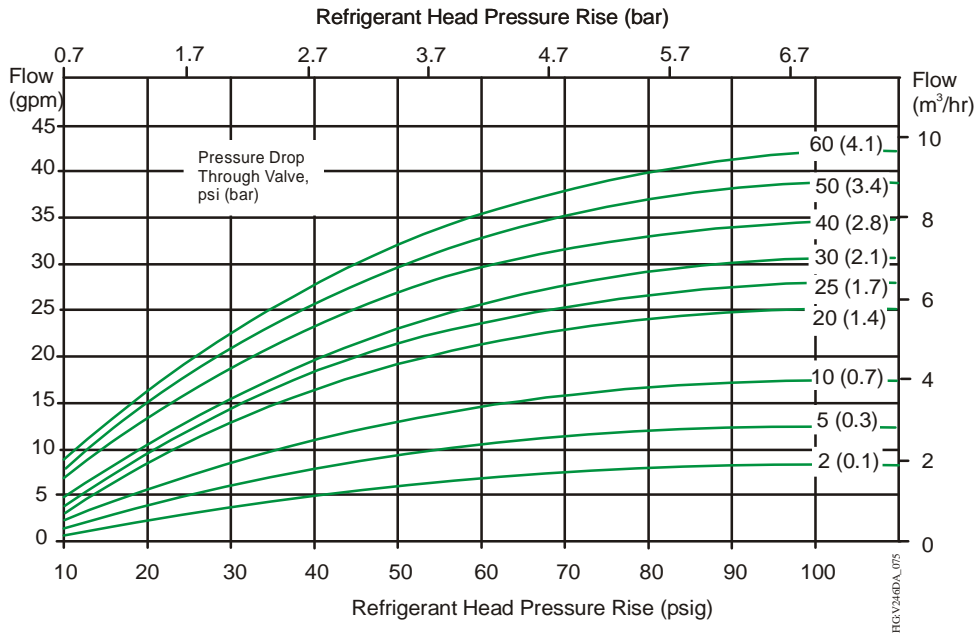

3/4 in. Direct Acting Valve Flowchart

V246 Series 2-Way Pressure-Actuated Water-Regulating Valves for High-Pressure Refrigerants (Continued)

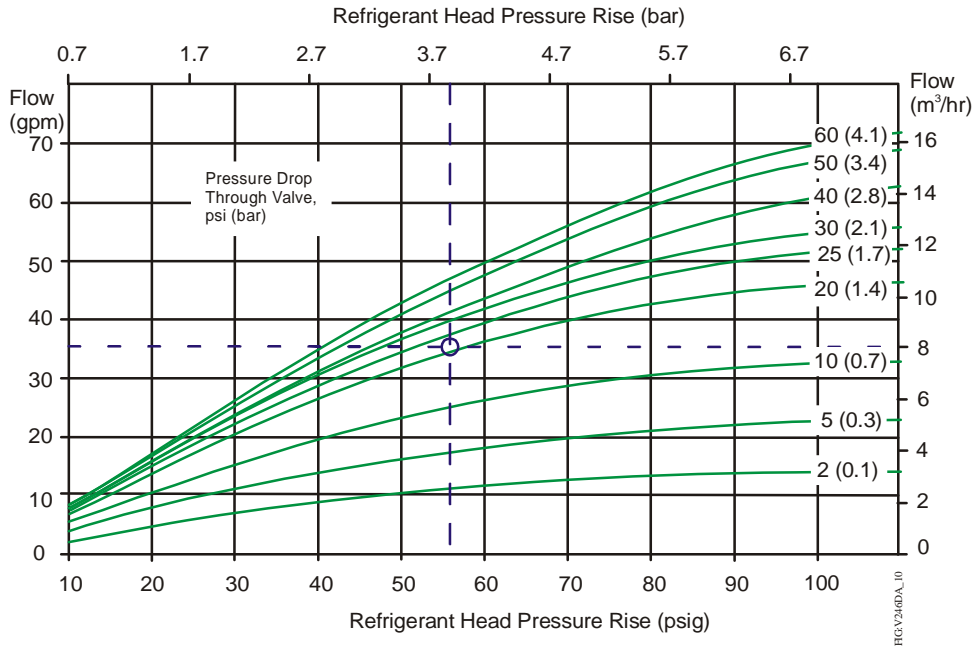

1 in. Direct Acting Valve Flowchart

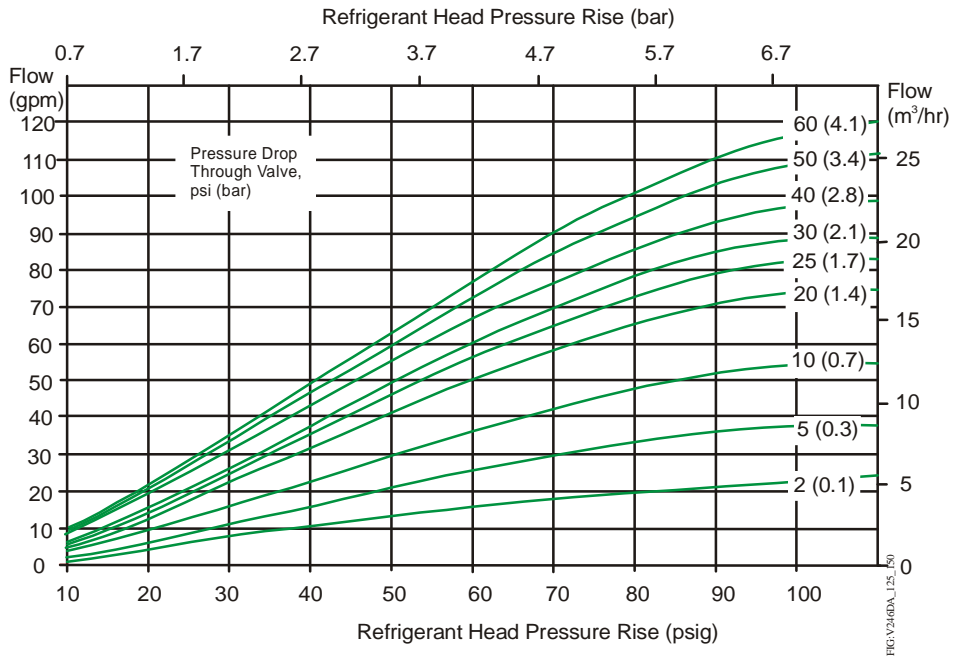

1-1/4 in. Direct Acting Valve Flowchart

V246 Series 2-Way Pressure-Actuated Water-Regulating Valves for High-Pressure Refrigerants (Continued)

Dimensions

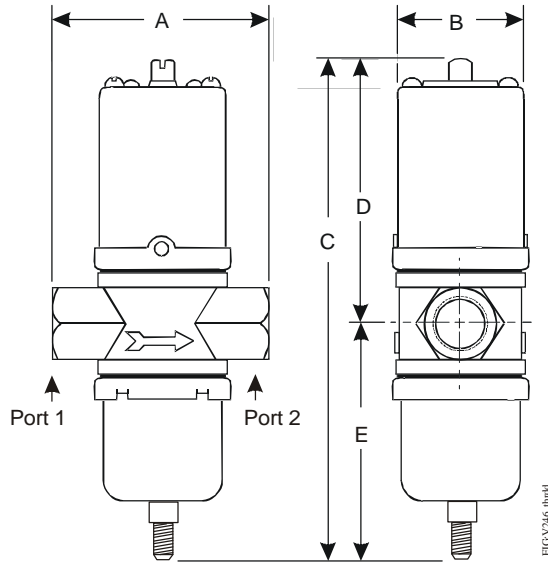

V246 Screw Connection Valves Dimensions

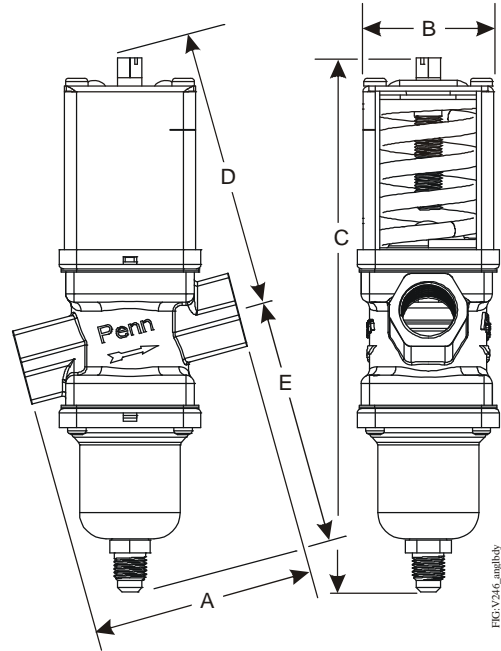

V246 Angle-Body Screw Connection Valves Dimensions

V246 Screw Connection Valves Dimensions

Valve Size	Dimensions in Inches (Millimeters)				
	A	B	C	D	E
3/8 in.	2-5/8 (67)	1-5/8 (41)	6-1/2 (166)	3-1/2 (89)	3 (77)
1/2 in.	3-1/16 (78)	2 (51)	7-3/16 (182)	3-13/16 (96)	3-3/8 (86)
3/4 in.	3-3/8 (86)	2-3/16 (55)	8 (203)	4-3/16 (106)	3-13/16 (98)
1 in.	4-3/4 (121)	2-13/16 (71)	10-1/2 (267)	5-15/16 (151)	4-9/16 (116)
1-1/4 in.	4-3/4 (121)	2-13/16 (71)	10-7/8 (276)	6-1/8 (156)	4-3/4 (121)

V246 Angle-Body Screw Connection Valves Dimensions

Valve Size	Dimensions in Inches (Millimeters)				
	A	B	C	D	E
3/8 in.	2-3/4 (70)	1-5/8 (41)	6-15/16 (176)	3-5/8 (92)	3-1/8 (80)
1/2 in.	3-1/8 (80)	2 (51)	7-1/2 (191)	3-7/8 (98)	3-1/2 (88)
3/4 in.	3-9/16 (90)	2-1/8 (55)	8-9/16 (217)	4-5/16 (110)	4 (101)

V246 Series 2-Way Pressure-Actuated Water-Regulating Valves for High-Pressure Refrigerants (Continued)

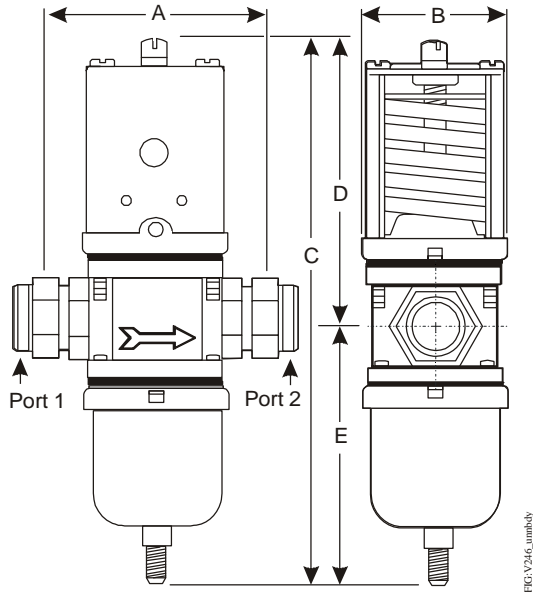

V246 Union Sweat Connection Valves Dimensions

V246 Union Sweat Connection Valves Dimensions

Valve Size	Dimensions in Inches (Millimeters)				
	A	B	C	D	E
1-1/4 in.	4-3/4 (121)	2-13/16 (71)	10-7/8 (276)	6-1/8 (156)	4-3/4 (121)

V246 Flange Valve, Commercial Service - Dimensions

Valve Size	Dimensions in Inches (Millimeters)							
	A	B	C	D	E	F	G	H
1-1/2 in.	5-5/16 (135)	9/16 (14)	6 -1/8 (156)	4-3/4 (121)	10-7/8 (276)	5-1/4 (133)	2-5/8 (67)	1-7/8 (48)

V246 Flange Valve, Commercial Service - Flange Specifications

Valve Size	Regional Version	Number of Holes	Hole Size	Bolt Circle
1-1/2 in.	North American	4	5/8 in. (16 mm)	3-7/8 in. (98 mm)
1-1/2 in.	European, DIN2533 Flanges	4	18 mm	110 mm

V246 Flange Valve, Maritime Service - Dimensions

Valve Size	Dimensions in Inches (Millimeters)							
	A	B	C	D	E	F	G	H
1-1/2 in.	5-5/16 (135)	9/16 (14)	6 -1/8 (156)	4-3/4 (121)	10-7/8 (276)	5-1/4 (133)	2-5/8 (67)	1-7/8 (48)

V246 Flange Valve, Maritime Service - Flange Specifications

Valve Size	Regional Version	Number of Holes	Hole Size	Bolt Circle
1-1/2 in.	North American	4	5/8 in. (16 mm)	3-7/8 in. (98 mm)
1-1/2 in.	European, DIN86021 Flanges	4	18 mm	110 mm

V246 Series 2-Way Pressure-Actuated Water-Regulating Valves for High-Pressure Refrigerants (Continued)

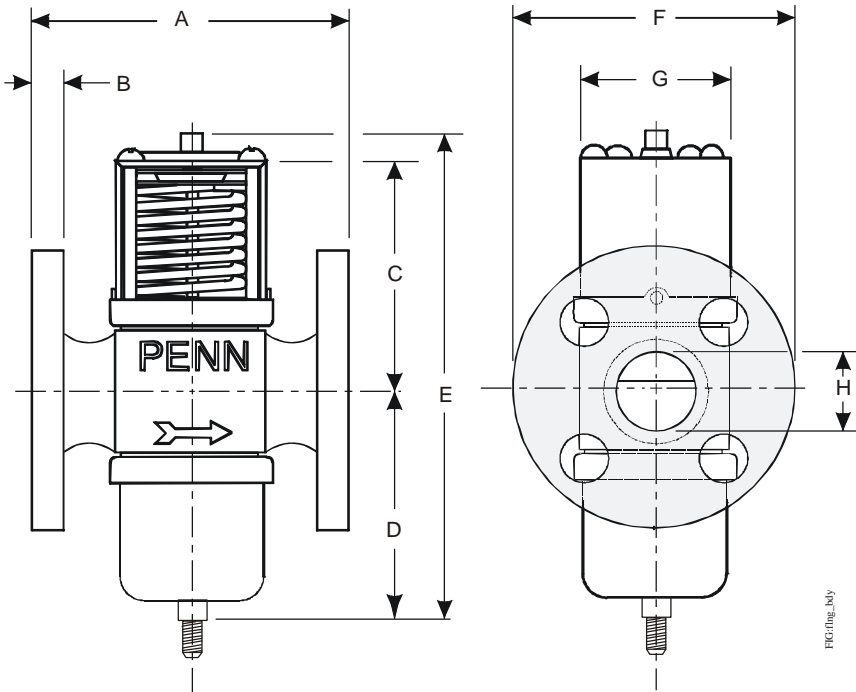

V246 Flange Valve Dimensions

Technical Specifications

Product	V246 Series 2-Way Pressure-Actuated Water-Regulating Valves for High-Pressure Refrigerants
Factory-Set Opening Point	200 psi (13.8 bar)
Maximum Working Pressure	630 psi (43.4 bar)
Opening Point Adjustment Range	200 to 400 psi (13.8 to 27.6 bar)
Media	150 psi (10.3 bar) Maximum, -4°F to 170°F (-20°C to 77°C) glycol/water or liquids with low freezing points that are compatible with valve materials