

UNINTERRUPTABLE POWER SUPPLY KIT

PSH600-UPS

600VA UPS Backup Power Control Center, 12" x 14" x 6" Metal Enclosure

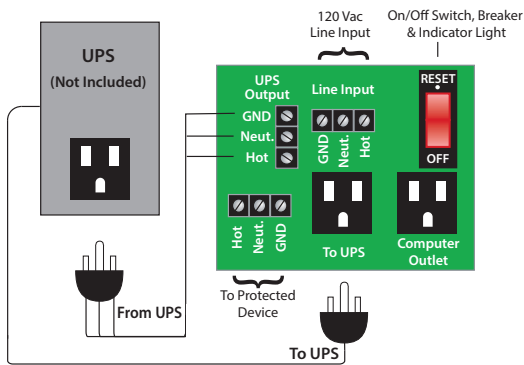

Shown With Cover



Shown Without Cover



SPECIFICATIONS

UPS

- UPS:** 600VA
- Backup Time:** 2.5 Min. @ Full 600 VA Load
10 Min. @ 1/2 Load
- Power Consumption:** Up to 3 Amp @120 Vac
- Max Load:** 330 Watt
- Frequency:** 50/60 Hz
- UPS Temperature Rating:** 32 to 104° F
- UPS Transfer Time:** 6ms
- Approvals:** UL Listed, UL1778

PSH2RB10

- Operating Temperature:** -30 to 140° F
- Humidity Range:** 5 to 95% (noncondensing)
- Main Breaker ON/OFF:** Switch / Breaker (10 Amp)
- Approvals:** UL Listed, UL916, C-UL, CE, RoHS
- Dimensions:** 12.000" H x 14.000" W x 6.000" D
Metal Housing with Screw Cover
- Origin:** Made of US and non-US parts

ESTIMATED BACKUP TIME VS. LOAD

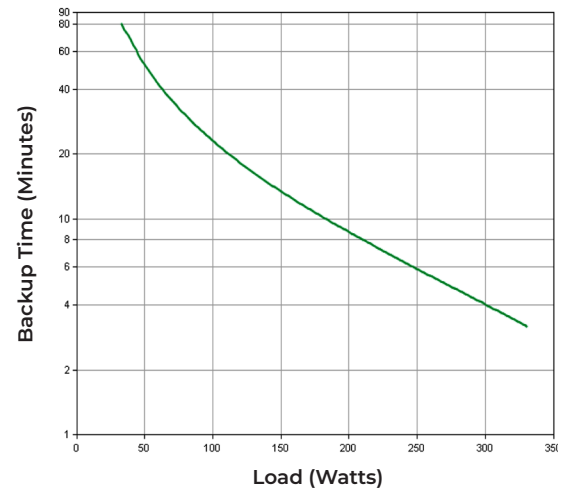

Notes:

To order without UPS, so that any other commercial UPS with appropriate ratings and within housing space limitations may be used, see model PSH2RB10.

To order interface board for replacement or for separate use, order model PSMN2RB10.

Average battery life: 3-5 years depending on the number of discharge cycles and environmental temperature

UPS may change based on quality and availability