

# Submittal

**1.5 Ton  
Convertible Air Handler  
A4AH6E19A1B30A**

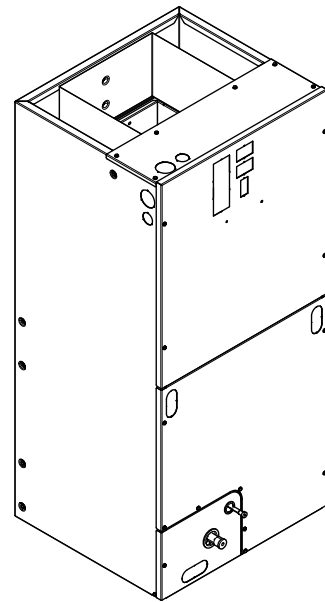



# Product Specifications

<b>MODEL</b>	A4AH6E19A1B30A
<b>RATED VOLTS/PH/HZ</b>	208-230/1/60
<b>RATINGS<sup>(a)</sup></b>	See O.D. Specifications
<b>INDOOR COIL — Type</b>	Plate Fin
Rows — F.P.I.	3 - 14
Face Area (sq. ft.)	4.37
Tube Size (in.)	3/8
Refrigerant Control	TXV
Drain Conn. Size (in.) <sup>(b)</sup>	3/4 NPT
<b>DUCT CONNECTIONS</b>	<b>See Outline Drawing</b>
<b>INDOOR FAN — Type</b>	Centrifugal
Diameter-Width (In.)	11 X 6
No. Used	1
Drive - No. Speeds	Direct - 4
CFM vs. in. w.g.	See Fan Performance Table
No. Motors — H.P.	1 - 1/3
Motor Speed R.P.M.	1050
Volts/Ph/Hz	208-230/1/60
F.L. Amps	2.8
<b>FILTER</b>	
Filter Furnished? <sup>(c)</sup>	No
<b>REFRIGERANT</b>	<b>R-410A</b>
Ref. Line Connections	Brazed

Coupling or Conn. Size — in. Gas	3/4
Coupling or Conn. Size — in. Liq.	3/8
<b>DIMENSIONS</b>	H x W x D
Crated (In.)	46 x 21 x 24
Uncrated	45-1/8 x 18-1/2 x 21-1/8
<b>WEIGHT</b>	
Shipping (Lbs.) / Net (Lbs.)	116/110

(a) These Air Handlers are A.H.R.I certified with various Split System Air Conditioners and Heat Pumps (AHRI STANDARD 210/240). Refer to the Split System Outdoor Unit Product Data Guides for performance data.

(b) 3/4" Male Plastic Pipe (Ref: ASTM 1785-76)

(c) Remote filter required.

## Minimum Airflow CFM

<b>A4AH6E19A1B30A</b>		
<b>Heater</b>	<b>Minimum Heat Speed Tap</b>	
	With Heat Pump	Without Heat Pump
BAYHTR1504BRK, BAYHTR1504LUG, BAYHTR1505BRK, BAYHTR1505LUG	Low	Low
BAYHTR1508BRK, BAYHTR1508LUG, BAYHTR1510BRK, BAYHTR1510LUG, BAYHTR3510LUG	High	Med

# Heater Pressure Drop Table

Airflow CFM	Number of Racks				Heater Racks	
	1	2	3	4	Heater Model	No. of Racks
	Air Pressure Drop — Inches W.G.					
1800	0.02	0.04	0.06	0.14	BAYHTR1504	1
1700	0.02	0.04	0.06	0.14	BAYHTR1505	1
1600	0.02	0.04	0.06	0.13	BAYHTR1508	2
1500	0.02	0.04	0.06	0.12	BAYHTR1510	2
1400	0.02	0.04	0.06	0.12	BAYHTR1517	3
1300	0.02	0.04	0.05	0.11	BAYHTR3510	3
1200	0.01	0.04	0.05	0.10	BAYHTR3517	3
1100	0.01	0.03	0.05	0.09	BAYHTR3515	3
1000	0.01	0.03	0.04	0.09	BAYHTR1523	4
900	0.01	0.03	0.04	0.08	BAYHTR1525	4
800	0.01	0.03				
700	0.01	0.02				
600	0.01	0.02				

# Performance and Electrical Data

1. See Product Data or Air Handler nameplate for approved combinations of Air Handlers and Heaters.
2. Heater model numbers may have additional suffix digits.

**Table 1. Air Flow Performance**

<b>A4AH6E19A1B30A</b>				
EXTERNAL STATIC (in w.g)	AIRFLOW			
	Speed Taps — 208 – 230 VOLTS			
	<b>High</b>	<b>Med-High</b>	<b>Med †</b>	<b>Low</b>
0.1	860	773	652	589
0.2	817	732	589	528
0.3	767	679	515	445
0.4	709	612	431	339
0.5	644	533	336	210
0.6	571	441	232	
0.7	491	336	116	

**Notes:**

1. Values are with wet coil, no filter, and no heaters
2. CFM Correction for dry coil = Add 3%
3. † = Factory Setting
4. Low = Taps 1-2, Med = Tap 3, Med-High= Tap 4, High = Tap 5

**Table 2. Electrical Data**

<b>A4AH6E19A1B30A</b>											
Heater Model No.	No. of Circuits/ Phases	240 Volt					208 Volt				
		Capacity		Heater Amps per Circuit	Minimum Circuit Ampacity	Maximum Overload Protection	Capacity		Heater Amps per Circuit	Minimum Circuit Ampacity	Maximum Overload Protection
		kW	BTUH				kW	BTUH			
No Heater				4.1 *	8	15			4.1 *	8	15
BAYHTR1504BRK BAYHTR1504LUG	1/1	3.8	13100	16.0	28	30	2.9	9800	13.8	25	25
BAYHTR1505BRK BAYHTR1505LUG	1/1	4.8	16400	20.0	33	35	3.6	12300	17.3	29	30
BAYHTR1508BRK BAYHTR1508LUG	1/1	7.7	26200	32.0	48	50	5.8	19700	27.7	42	45
BAYHTR1510BRK BAYHTR1510LUG	1/1	9.6	32800	40.0	58	60	7.2	24600	34.6	51	60
BAYHTR3510LUG	1/3	9.6	32800	23.1	36	40	7.2	24600	20.0	32	35

\* = Motor Amps

# Features and Benefits

- Galvanized metal cabinet with captured foil face insulation
- 2% or less air leakage
- R-4.2 Insulating Value
- Multi-Position UP/Down Flow, Horizontal Left /Right
- ALL Aluminum Coil with Enhanced Patented Coil Fin
- Electric Heaters with polarized plug connections (sold as accessory)
- R-410A Thermal Expansion Valve
- ECM Motor (**3.5 – 5 Ton Models**)

- Low Voltage Pigtail Connections
- Draw Through Design
- Horizontal Drain pan
- Single Color
- Fused 24V Power
- **5 year warranty**
- **Optional extended warranty available**

***Important:*** Condensate management kit is required for all 5 ton air handler models installed in downflow applications.

**About Trane and American Standard Heating and Air Conditioning**

Trane and American Standard create comfortable, energy efficient indoor environments for residential applications. For more information, please visit [www.trane.com](http://www.trane.com) or [www.americanstandardair.com](http://www.americanstandardair.com).

---



The manufacturer has a policy of continuous data improvement and it reserves the right to change design and specifications without notice. We are committed to using environmentally conscious print practices.