

TAG: \_\_\_\_\_

# Submittal

## Wall-Mount Air Handlers 1-1/2 – 3 Ton Cooling/ Heat Pump

(Limited heat pump combinations. See AHRI for details.)

- TMM4B0A18S21SA
- TMM4B0A24S21SA
- TMM4B0B30S21SA
- TMM4B0B36S31SA

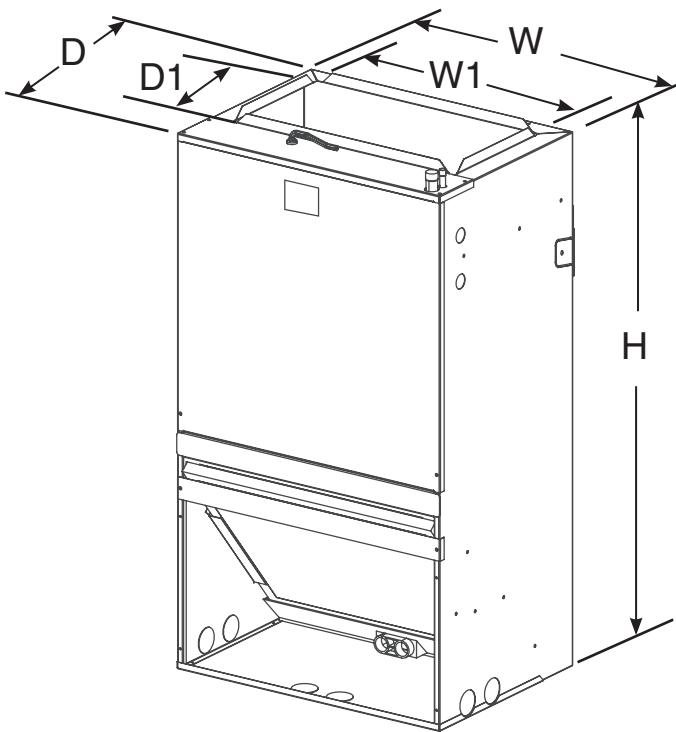

### Dimensional and Clearance Data

MINIMUM UNIT CLEARANCE TABLE		
	TO COMBUSTIBLE MATERIAL (REQUIRED)	SERVICE CLEARANCE (RECOMMENDED)
SIDES	0"	0"
FRONT	0"	24"
BACK	0"	0"
INLET DUCT	0"	0"
OUTLET DUCT	0**	
* 0" FOR THE FIRST 3 FT. OF OUTLET DUCT WHEN ELECTRIC HEATERS ARE INSTALLED		

PRODUCT DIMENSIONS inch (mm)								Unit weight/ Shipping Weight [LBS(kg)]
	Height H	Width W	Width W1	Depth D	Depth D1	Flow Control	Gas Line Braid	
TMM4B0A18S21SA	36-1/2" (928)	20-1/2" (522)	16-5/8" (422)	15" (381)	9-1/2" (242)	Orifice	3/4"	88/97 (40/44)
TMM4B0A24S21SA	36-1/2" (928)	20-1/2" (522)	16-5/8" (422)	15" (381)	9-1/2" (242)	Orifice	3/4"	88/97 (40/44)
TMM4B0B30S21SA	39-1/2" (1004)	22" (559)	18-3/4" (477)	19" (483)	9-1/2" (242)	Orifice	3/4"	106/119 (48/54)
TMM4B0B36S31SA	39-1/2" (1004)	22" (559)	18-3/4" (477)	19" (483)	9-1/2" (242)	Orifice	3/4"	106/119 (48/54)

# PRODUCT SPECIFICATIONS

MODEL	TMM4B0A18S21SAA	TMM4B0A24S21SAA	TMM4B0B30S21SAA	TMM4B0B36S31SAA
RATED VOLTS/PH/HZ.	208-230/1/60	208-230/1/60	208-230/1/60	208-230/1/60
RATINGS	See O.D. Specifications	See O.D. Specifications	See O.D. Specifications	See O.D. Specifications
INDOOR COIL — Type	Plate Fin	Plate Fin	Plate Fin	Plate Fin
Rows — F.P.I.	5 - 11	5- 11	5- 14	5- 14
Face Area (sq. ft.)	2.20	2.20	3.00	3.00
Tube Size (in.)	9/32	9/32	9/32	9/32
Refrigerant Control	Orifice	Orifice	Orifice	Orifice
Drain Conn Size (in.)	3/4 NPT	3/4 NPT	3/4 NPT	3/4 NPT
DUCT CONNECTIONS	See Outline Drawing	See Outline Dawing	See Outline Drawing	See Outline Drawing
INDOOR FAN — Type	Centrifugal	Centrifugal	Centrifugal	Centrifugal
Diameter-Width (In.)	10-5/6 X 6-1/7	10-5/6 X 6-1/7	10-3/5 X 9-10/7	10-3/5 X 9-10/7
No. Used	1	1	1	1
Drive - No Speeds	Direct - 3	Direct - 3	Direct - 3	Direct - 3
CFM vs. in. w.g.	See Fan Performance Table	See Fan Performance Table	See Fan Performance Table	See Fan Performance Table
No. Motors — H.P.	1 - 1/6	1 - 1/4	1 - 1/3	1 - 1/2
Motor Speed R.P.M.	1075	1075	1075	1075
Volts/Ph/Hz	208-230/1/60	208-230/1/60	208-230/1/60	208-230/1/60
F.L. Amps	0.8	1.0	1.28	1.8
FILTER				
Filter Furnished?	No	No	No	No
Type Recommended	Throwaway	Throwaway	Throwaway	Throwaway
No.-Size-Thickness	1 - 16X 20 - 1 in.	1 - 16X 20 - 1 in.	1 - 20X 20 - 1 in.	1 - 20X 20 - 1 in.
REFRIGERANT	R-410A	R-410A	R-410A	R-410A
Ref Line Connections	Brazed	Brazed	Brazed	Brazed
Coupling or Conn. Size — in. Gas	3/4	3/4	3/4	3/4
Coupling or Conn. Size — in. Liq.	3/8	3/8	3/8	3/8
DIMENSIONS	H x W x D	H x W x D	H x W x D	H x W x D
Crated (In.)	39-3/8×22-6/7×17-1/3	39-3/8×22-6/7×17-1/3	42-4/7×24-1/4×21-2/7	42-4/7×24-1/4×21-2/7
Uncrated	36-1/2×20-1/2×15	36-1/2×20-1/2×15	39-1/2×22×19	39-1/2×22×19
WEIGHT				
Shipping (Lbs.)/Net (Lbs.)	97/88	97/88	119/106	119/106

# Performance and Electrical Data – TMM4B0A18–B36

## AIR FLOW PERFORMANCE (Standard CFM)

Model Number	Motor Speeds		EXTERNAL STATIC PRESSURE (INWC.)								
			0	0.1	0.2	0.3	0.4	0.5	0.6	0.7	0.8
TMM4B0A18S21SAA	Low	CFM	603	562	525	485	443	393	-	-	-
		Watts	216	212	208	202	197	190	-	-	-
		Amps	1.1	1.1	1.1	1	1	1	-	-	-
	Medium	CFM	695	656	620	581	540	498	440	380	-
		Watts	227	224	220	216	210	203	196	188	-
		Amps	1.2	1.1	1.1	1.1	1.1	1	1	1	-
	High	CFM	813	775	731	692	653	609	560	501	424
		Watts	284	279	273	267	261	253	245	237	227
		Amps	1.5	1.4	1.4	1.4	1.3	1.3	1.3	1.2	1.2
TMM4B0A24S21SAA	Low	CFM	676	640	602	563	523	499	-	-	-
		Watts	238	232	226	222	217	214	-	-	-
		Amps	1.2	1.2	1.2	1.1	1.1	1.1	-	-	-
	Medium	CFM	845	801	759	716	675	626	573	510	-
		Watts	276	271	266	261	256	252	247	242	-
		Amps	1.4	1.4	1.4	1.3	1.3	1.3	1.3	1.2	-
	High	CFM	947	895	847	799	753	704	655	592	530
		Watts	343	336	329	322	315	309	303	297	291
		Amps	1.8	1.7	1.7	1.6	1.6	1.6	1.5	1.5	1.5
TMM4B0B30S21SAA	Low	CFM	992	952	912	873	828	782	728	656	627
		Watts	327	318	308	299	290	281	273	264	256
		Amps	1.7	1.6	1.6	1.5	1.5	1.4	1.4	1.4	1.3
	Medium	CFM	1211	1165	1114	1065	1016	960	899	833	748
		Watts	359	353	346	338	330	321	311	300	289
		Amps	1.8	1.8	1.8	1.7	1.7	1.6	1.6	1.5	1.5
	High	CFM	1367	1312	1252	1192	1131	1063	990	908	821
		Watts	450	440	430	420	409	397	384	371	358
		Amps	2.3	2.3	2.2	2.1	2.1	2	2	1.9	1.8
TMM4B0B36S31SAA	Low	CFM	1149	1105	1056	1008	960	909	856	791	726
		Watts	392	380	368	356	344	332	321	309	297
		Amps	2	1.9	1.9	1.8	1.8	1.7	1.6	1.6	1.5
	Medium	CFM	1298	1252	1198	1147	1094	1037	976	910	842
		Watts	400	390	380	370	360	350	340	329	319
		Amps	2	2	1.9	1.9	1.8	1.8	1.7	1.7	1.6
	High	CFM	1397	1345	1290	1263	1196	1116	1051	980	907
		Watts	460	452	443	433	422	410	396	382	366
		Amps	2.4	2.3	2.3	2.2	2.2	2.1	2	2	1.9

Shaded boxes represent airflow outside the required 300-450 cfm/ton.

**NOTES:**

1. Airflow based upon dry coil at 230V with no electric heat, no filter.
2. Airflow is equivalent for front or bottom return configurations.
3. SCFM is nearly the same with cooling performance airflow, the gap is in the 1 to 2%.

<b>TMM4B0A18S21SA – ELECTRICAL DATA</b>											
Heater Model No	No. of Circuits/ Phases	240 Volt					208 Volt				
		Capacity		Heater Amps per Circuit	Minimum Circuit Ampacity	Maximum Overload Protection	Capacity		Heater Amps per Circuit	Minimum Circuit Ampacity	Maximum Overload Protection
		kW	BTUH				kW	BTUH			
No Heater					1.0	15				1.0	15
BAYHTRM505BRKA*	1/1	5	17100	20.8	27.1	30	3.8	12800	18.0	23.6	25
BAYHTRM508BRKA*	1/1	7.5	25600	31.2	40.1	45	5.6	19200	27.1	34.9	40
BAYHTRM510BRKA*	1/1	10	34100	41.7	53.1	60	7.5	25600	36.1	46.2	50

<b>TMM4B0A24S21SA – ELECTRICAL DATA</b>											
Heater Model No	No. of Circuits/ Phases	240 Volt					208 Volt				
		Capacity		Heater Amps per Circuit	Minimum Circuit Ampacity	Maximum Overload Protection	Capacity		Heater Amps per Circuit	Minimum Circuit Ampacity	Maximum Overload Protection
		kW	BTUH				kW	BTUH			
No Heater					1.3	15				1.3	15
BAYHTRM505BRKA*	1/1	5	17100	20.8	27.3	30	3.8	12800	18.0	23.9	25
BAYHTRM508BRKA*	1/1	7.5	25600	31.2	40.4	45	5.6	19200	27.1	35.2	40
BAYHTRM510BRKA*	1/1	10	34100	41.7	53.4	60	7.5	25600	36.1	46.4	50

<b>TMM4B0B30S21SA – ELECTRICAL DATA</b>											
Heater Model No	No. of Circuits/ Phases	240 Volt					208 Volt				
		Capacity		Heater Amps per Circuit	Minimum Circuit Ampacity	Maximum Overload Protection	Capacity		Heater Amps per Circuit	Minimum Circuit Ampacity	Maximum Overload Protection
		kW	BTUH				kW	BTUH			
No Heater					1.6	15				1.6	15
BAYHTRM505BRKA*	1/1	5	17100	20.8	27.7	30	3.8	12800	18.0	24.2	25
BAYHTRM508BRKA*	1/1	7.5	25600	31.2	40.7	45	5.6	19200	27.1	35.5	40
BAYHTRM510BRKA*	1/1	10	34100	41.7	53.7	60	7.5	25600	36.1	46.8	50

<b>TMM4B0B36S31SA – ELECTRICAL DATA</b>											
Heater Model No	No. of Circuits/ Phases	240 Volt					208 Volt				
		Capacity		Heater Amps per Circuit	Minimum Circuit Ampacity	Maximum Overload Protection	Capacity		Heater Amps per Circuit	Minimum Circuit Ampacity	Maximum Overload Protection
		kW	BTUH				kW	BTUH			
No Heater					2.3	15				2.3	15
BAYHTRM505BRKA*	1/1	5	17100	20.8	28.3	30	3.8	12800	18.0	24.9	25
BAYHTRM508BRKA*	1/1	7.5	25600	31.2	41.4	45	5.6	19200	27.1	36.2	40
BAYHTRM510BRKA*	1/1	10	34100	41.7	54.4	60	7.5	25600	36.1	47.4	50

# Mechanical Specifications

---

## STANDARD FEATURES

- Front or bottom return air
- Painted finish on galvanized steel
- Sturdy polycarbonate drain pans
  - The TMM4 wall mount air handler has factory installed drain pan and is shipped for upflow applications only.
- 208/230 - VAC operation
- Multi-speed direct drive blower
  - PSC motor
- Stud or wall mounting tabs
- Fully insulated cabinet
- 3/4" NPT primary and secondary drains
- **3 year warranty**
- **10-year warranty registered**
- **Optional extended warranty available**
- **All – aluminum tubes & fins**

## OPTIONAL ACCESSORIES

- 5, 7.5, and 10 kW single phase electric heaters
  - Circuit breakers are standard on all single phase 5, 7.5, and 10 kW heaters.
- R-410 TXV kit - 4AYTXVH3G2436
- R-22 TXV conversion kit - 2AYTXVH3G2436
- Front louver panel 20.5" width - BAYFRTLLOUPNL20 (1-Pack)
- Front louver panel 22" width - BAYFRTLLOUPNL22 (1-Pack)
- Return air / service wall panel - BAYTMMWALLPNL1 (20-Pack)

About Trane and American Standard Heating and Air Conditioning  
Trane and American Standard create comfortable, energy efficient indoor environments for residential applications. For more information, please visit [www.trane.com](http://www.trane.com) or [www.americanstandardair.com](http://www.americanstandardair.com)



The AHRI Certified mark indicates company participation in the AHRI Certification program. For verification of individual certified products, go to [ahridirectory.org](http://ahridirectory.org).

The manufacturer has a policy of continuous data improvement and it reserves the right to change design and specifications without notice. We are committed to using environmentally conscious print practices.