

Product Catalog

Packaged Rooftop Air Conditioners Foundation[™]

Cooling and Gas/Electric
15 to 25 Tons, 60 Hz



Introduction

Packaged Rooftop Air Conditioners



Through the years, American Standard has designed and developed the most complete line of Packaged Rooftop products available in the market today.

American Standard customers demanded a product that provided exceptional reliability, was easy to install, and was competitively priced.

American Standard listened and is proud to introduce the new Foundation™ Light Commercial rooftop unit. With Foundation, American Standard continues to provide the highest standards in quality and reliability, comfort, performance, and ease of installation. light commercial products.

Copyright

This document and the information in it are the property of Trane, and may not be used or reproduced in whole or in part without written permission. Trane reserves the right to revise this publication at any time, and to make changes to its content without obligation to notify any person of such revision or change.

Trademarks

All trademarks referenced in this document are the trademarks of their respective owners.

Revision History

- Updated General data tables.
- Updated Evaporator fan performance tables.
- Digit K option removed.
- Minor edits to the document.

Features and Benefits

Foundation™ has features and benefits that make it first class in the light commercial rooftop market. Designed with input from field contractors and technicians, its convertible airflow and ease of installation are outstanding.

Standard and Optional Features

	Large Foundation		
	Standard	Options ^(a)	
		Factory Installed	Field Installed
1-year Limited Parts Warranty	X		
5-year Limited Compressor Warranty	X		
5-year Limited Aluminized Heat Exchanger Warranty	X		
10-year Limited Stainless Steel Heat Exchanger Warranty		X	
Barometric Relief Damper		X	X
Belt Drive Motors	X		
CO ₂ sensor - Demand Control Ventilation (DCV)			X
Colored Connectors and Wiring	X		
Complete Coat Microchannel Condenser Coil		X	
Compressor Discharge Temperature Limit (DTL)	X		
Condensate Overflow Switch		X	X
Convertible Airflow	X ^(b)		
Crankcase Heaters	X ^(c)		X ^(c)
Disconnect Switch		X	X
Easy Access Low Voltage Connections	X		
Economizer (Downflow)		X	X
Electric Heaters		X	X
Filters	X		
Hail/Vandal Guards			X
High Efficiency Filters (MERV 13)			X
High Pressure Control	X		
High Static Motor Kit ^(d)		X	X
Insulation - 1/2-inch, 1-lb Density	X		
IAQ Dual Sloped and Removable Drain Pans	X		
Liquid Line Refrigerant Drier	X		
Low Ambient Cooling			X
Low Leak Economizer		X	X
Low Pressure Control	X		
Low Static Drive Kit			X
Low Voltage Circuit Protection	X		
LP Conversion Kit			X
Manual Outside Air Damper		X	X
Motorized 2-Position Damper		X	X

Features and Benefits

	Large Foundation		
	Standard	Options ^(a)	
		Factory Installed	Field Installed
Multi-Speed Indoor Fans	X		
Multi-Speed Oversized		X	
Phase Loss/Reversal Monitor	X		
Powered Exhaust			X
Quick Access Panels	X		
Remote Potentiometer			X
Scroll Compressors	X		
Single Point Power	X		
Single Side Service	X		
Standardized Components	X		
Thermal Expansion Valve	X		
Through-the-base electrical, gas connection provisions	X		

- (a) Refer to model number description for option availability or contact Product Support.
- (b) Foundation units ship in the downflow configuration. A horizontal conversion kit, consisting of two downflow duct covers, is needed to convert the unit from a downflow to a horizontal airflow configuration
- (c) Crankcase heaters are standard on 15 to 20 ton units. Crankcase heaters are a field installed accessory on 25 ton units.
- (d) Available on constant volume units only. See Accessories chapter for more information.

Outstanding Standard Features

Colored And Numbered Wiring

Save time and money tracing wires and diagnosing the unit.

Compressors

Foundation™ contains the best compressor technology available to achieve the highest possible performance. Dual stages from manifold compressors are outstanding for humidity control and part load cooling conditions.

Controls – Electromechanical

This 24-volt control includes the control transformer and contactor pressure lugs for power wiring.

Convertible Units

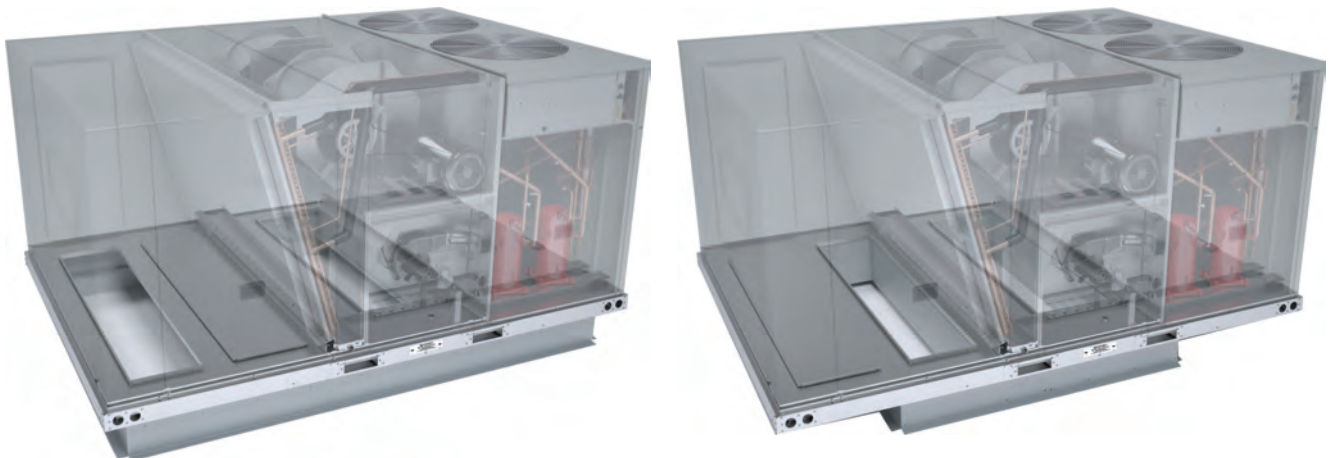

Foundation™ units ship in the downflow configuration. A horizontal conversion kit, consisting of two downflow duct covers, is needed to convert the unit from a downflow to a horizontal airflow configuration. Units come complete with horizontal duct flanges so the contractor doesn't have to field fabricate them. These duct flanges are a time and cost saver. Units also have the ability to fit American Standard and other competitors roof curbs (Carrier). In a matter of minutes, you can go from the American Standard configuration to the Carrier configuration by simply changing the return air opening plate. This design allows for easy field conversion and eliminates the need for costly adapter curbs.

Crankcase Heaters (15 - 20 Tons)

These band heaters provide improved compressor reliability by warming the oil to prevent migration during off-cycles or low ambient conditions.

Discharge Line Thermostat

A bi-metal element discharge line thermostats installed as a standard feature on the discharge line of each compressor. This standard feature provides extra protection to the compressors against high discharge temperatures in case of loss of charge, extremely high ambient and other conditions which could drive the discharge temperature higher.

Efficiency

Product efficiencies meet the requirements of ASHRAE 90.1.

Easy Access Low Voltage Terminal Board

Foundation™ Low Voltage Terminal Board is mounted outside the main electrical control cabinet. It is extremely easy to locate and attach the thermostat control wiring and also test operation of all unit functions. This is another cost and time saving installation feature.

Insulation

All panels in the evaporator section of the unit have foil-faced, glass fiber insulation. All base panels have foil-faced, glass fiber insulation. All edges are either captured or sealed to ensure no insulation fibers get into the airstream.

Frostat™

This switch monitors coil temperature to prevent evaporator icing and protect the compressor.

Heat Exchanger

The cabinet features a tubular heat exchanger in low, medium and high heat capacities – all available for vertical and horizontal discharge directions. The heat exchanger is fabricated using aluminized steel burners and corrosion-resistant, aluminized steel tubes as standard on all models. As part of the heat exchanger assembly, an induced draft blower is used to pull the gas mixture through the burner tubes. A direct spark ignition system, which doubles as a safety device to prove the flame, is used to ignite the gas mixture.

Locking Safety Device with Anti-Short Cycle Timer

This device monitors compressor safety switch trips to prevent short cycling, protecting the compressor. A manual reset is required after a fourth safety switch trip.

Low Ambient Cooling

All Foundation units have cooling capabilities down to 45°F as standard.

Low Voltage Connections

The wiring of the low voltage connections to the unit and the thermostat is as simple as R-R, G-G, Y-Y, and W-W. This simplified system makes it easy for the installer to wire.

Features and Benefits

Microchannel Condenser Coil

Microchannel condensing coils are all-aluminum coils with fully-brazed construction. This design reduces risk of leaks and provides increased coil rigidity — making them more rugged on the jobsite. Their flat streamlined tubes with small ports and metallurgical tube-to-fin bond allow for exceptional heat transfer. Microchannel all-aluminum construction provides several additional benefits:

- Light weight (simplifies coil handling)
- Easy to recycle
- Minimize galvanic corrosion

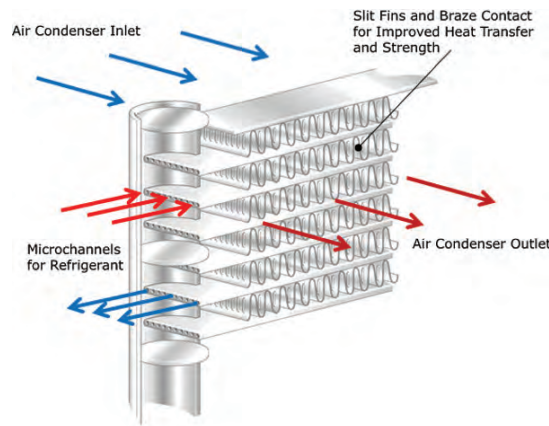

Motors

All indoor fan motors are belt drive as standard.

Multi-Speed Indoor Fan System

Multi-speed indoor fan system is designed for use in applications for meeting the minimum requirement of CA Title 24. This system incorporates a multi-speed fan control to change the speed of the fan to 66% of full airflow based off compressor stages.

Pressure Cutouts

Low and high pressure cutouts are standard on all Foundation™ models.

Phase Monitor

Foundation features a three-phase line monitor module that protects against phase loss, phase reversal and phase unbalance. It is intended to protect compressors from reverse rotation. It has an operating input voltage range of 180–600 Vac, and LED indicators for ON and FAULT. There are no field adjustments and the module will automatically reset from a fault condition.

Quick-Access Panels

Remove three or less screws for access to the standardized internal components and wiring.

Quick-Adjust Fan Motor Mounting Plate

With the quick-adjust slider plate, the belt and sheaves can be quickly adjusted without moving the mounted fan motor. This results in reduced time spent on routine maintenance.

Single Point Power

A single electrical connection powers the unit and all on-board options.

Single Side Service

Single side service is standard on all units.

Sloped Drain Pans

Every Foundation™ unit has a non-corrosive, sloped drain pan made of rigid PVC - standard on all units - that is removable for easy cleaning.

Standardized Components

Components are placed in the same location on all Foundation units. Familiarize yourself with one Foundation and you are familiar with every Foundation. Due to standardized components throughout the Foundation line, contractors/owners can stock fewer parts.

Variety of Options

Factory Installed Options

Complete Coat™ Condenser Coil

The cathodic epoxy type electrodisposition coating is formulated for high edge build to a number of different types of heat exchangers. The coating is selected to provide excellent resistance and durability to corrosive effects of alkalis, acids, alcohols, petroleum, seawater, salt air, and corrosive environments.

Stainless Steel Heat Exchanger

The optional stainless steel heat exchanger is constructed of 409 stainless steel tubes and 439 stainless steel burners. It is resistant to corrosion and oxidation and easy to clean. The high strength to weight ratio allows for high ventilation rates with gas units and comes standard with a modulating gas heat option. With this option, a 10-year stainless steel heat exchanger warranty is standard.

Third Side Fork Access

This option adds fork openings on the condenser end of the unit for ease of maneuvering the unit through narrow openings.

Factory or Field Installed Options

Barometric Relief

Designed to be used on downflow units, barometric relief is an unpowered means of relieving excess building pressure.

Condensate Overflow Switch

A condensate overflow switch is available to shut the unit down in the event that the condensate drain becomes clogged. This option protects the unit from water overflowing from the drain pan and entering the base of the unit.

Disconnect Switch

This accessory can be utilized as a convenient way to stock standard product without a disconnect and have the ability to use the through the base/disconnect offering. The standard disconnect is non-fused, 3-pole, case molded switch.

Economizer - Downflow

Economizers are equipped with either dry bulb, reference, or comparative enthalpy sensing. These economizers provide free cooling as the outdoor temperature and/or humidity decreases. Correctly installed, they offer valuable energy savings.

Factory-installed economizers save time and ensure proper installation.

Note: *Factory-installed economizers require some field set-up.*

Electric Heaters

Electric heat modules are available within the basic unit. If ordering the through-the-base electrical option with an electrical heater, the heater must be factory installed.

Features and Benefits

Low Leak Economizer with Fault Detection and Diagnostics - Downflow

This economizer meets the damper leakage requirements for ASHRAE 90.1, IECC, and California Title 24 standards (3 cfm/ft² at 1.0 in. w.g. for outside air dampers and 4 cfm/ft² for return dampers).

Also, included as required per California Title 24:

- Fault Detection and Diagnostics system - provides detection of economizer faults. Barometric relief must be field installed with this option.
- Occupant Controlled Smart Thermostat (OCST) Connection - user-provided thermostat allows remote monitoring of economizer faults, and also provides the capability to receive load shedding commands from the utility company.

Manual Outside Air Damper

A 0-25 percent manual air damper is available.

Motorized Outside Air Damper

A 0–50 percent motorized outside air dampers is available.

Reference or Comparative Enthalpy

Measures and communicates humidity while maximizing comfort control.

Through-the-Base Electrical Utility Access

An electrical service entrance shall be provided allowing access for both control and main power connections inside the curb and through the base of the unit. This option will allow for field installation of liquid-tight conduit and an external field installed disconnect switch.

Factory provided through the base openings simplify wiring and piping. Because these utility openings frequently minimize the number of roof penetrations, the integrity of roofing materials is enhanced.

Through-the-Base Gas Piping (Gas Heat Units Only)

This option shall have all piping necessary including, black steel, manual gas shut-off valve, elbows, and union. This assembly will require minor field labor to install.

Field Installed Options

CO₂ Sensor - Demand Control Ventilation (DCV)

Demand-controlled ventilation (DCV) is a control strategy that responds to the actual demand (need) for ventilation by regulating the rate at which the HVAC system brings outdoor air into the building. A CO₂ sensor measures the concentration (parts per million, ppm) of CO₂ in the air. As the CO₂ concentration changes, the outside air damper modulates to meet the current ventilation needs of the zone. DCV is a passive system; direct control of the indoor fan is not possible with standard or low leak economizers. The CO₂ sensor kit is available as a field installed accessory.

Crankcase Heaters (25 Tons)

These band heaters provide improved compressor reliability by warming the oil to prevent migration during off-cycles or low ambient conditions.

Economizer - Horizontal

Economizers are equipped with either dry bulb or reference or comparative enthalpy sensing. These economizers provide free cooling as the outdoor temperature and/or humidity decreases. Correctly installed, they offer a valuable energy savings.

High Altitude Kit

While recommended for units applied above 2,000 feet, domestic contractors should consult with local authority on best practice. High altitude kits contain gas orifices that derate the gas input rate (Btuh/r) by 10%.

Low Leak Economizer with Fault Detection and Diagnostics - Horizontal

This economizer meets the damper leakage requirements for ASHRAE 90.1, IECC, and California Title 24 standards (3 cfm/ft² at 1.0 in. w.g. for outside air dampers and 4 cfm/ft² for return dampers).

Also, included as required per California Title 24:

- Fault Detection and Diagnostics system - provides detection of economizer faults. Barometric relief must be field installed with this option.
- Occupant Controlled Smart Thermostat (OCST) Connection - user-provided thermostat allows remote monitoring of economizer faults, and also provides the capability to receive load shedding commands from the utility company.

LP Conversion Kit

Provided for field conversion of gas heat units from natural gas to propane.

Power Exhaust

This option is available on downflow units and provides exhaust of the return air, when using a downflow economizer, to maintain proper building pressurization. This is an excellent option for relieving most building overpressurization problems.

Remote Potentiometer

When installed in the economizer control circuitry, this accessory provides a method to remotely adjust the minimum damper position.

Roof Curbs

Available for downflow units. Only one roof curb for the entire Foundation™ line simplifies curb selection.

Static Drive Accessories

Available on many models, this high and low static drive accessories extend the capability of the standard motor. Avoid expensive motors by installing this optimized sheave accessory.

Thermostats

Available in programmable and non-programmable.

Tool-less Hail Guards



Tool-less, hail protection quality coil guards shall be field-installed for condenser coil protection. This option protects the condenser coil from vandalism and/or hail damage.

Other Benefits

Cabinet Integrity

For added water integrity, Foundation has a raised 1-1/8 inch lip around the supply and return of the downflow units to prevent water from blowing into the ductwork.

Easy to Install, Service and Maintain

Because today's owners are very cost-conscious when it comes to service and maintenance, Foundation was designed with direct input from service contractors. This valuable information helped to design a product that would get the service technician off the job quicker and save the owner money. Foundation does this by offering outstanding standard features enhanced by a variety of factory and

Features and Benefits

field installed options, multiple control options, rigorously tested proven designs and superior product and technical support.

Outstanding Flexibility

The Foundation unit has the ability to adapt to specific Carrier WeatherMaker™ models without costly adapter curbs. This will save contractors money and make the installation an ease.

Rigorous Testing

All of Foundation's designs were rigorously rain tested at the factory to ensure water integrity. Foundation units incorporate either a one piece top or the Trane-Tite-Top (T3). Each part of the top overlaps in such a way that water cannot leak into the unit. These overlapped edges are gasketed and sealed to ensure superior water integrity.

Actual shipping tests were performed to determine packaging requirements. Units were test shipped around the country to determine the best packaging. Factory shake and drop tests were used as part of the package design process to help assure that the unit arrives at the job site in top condition.

Rigging tests include lifting a unit into the air and letting it drop one foot, assuring that the lifting lugs and rails hold up under stress. For the microchannel coils, the supplier will perform the leak check at 450 psig. The completely assembled refrigerant system is leak tested at a minimum of 225 psig with a refrigerant and nitrogen mixture.

All parts are inspected at the point of final assembly. Sub-standard parts are identified and rejected immediately. Every unit receives a 100% unit run test before leaving the production line to make sure it lives up to rigorous Trane requirements.

Unmatched Support

Trane Sales Representatives are a Support Group that can assist you with:

- Product
- Special Applications
- Application
- Specifications
- Service
- Computer Programs and much more
- Training

Application Considerations

Application of this product should be within the cataloged airflow and cooling considerations.

Barometric Relief

This product line offers an optional barometric relief damper for use in conjunction with economizer option. This accessory consists of gravity dampers which open with increased pressure. As building pressure increases, the pressure in the unit return air section also increases, opening the dampers and relieving the conditioned space.

Notes:

- *The effectiveness of barometric relief damper during economizing operation is system related.*
- *Pressure drop of the return air system should be considered to control building pressurization.*

Clearance Requirements

The recommended clearances identified with unit dimensions should be maintained to ensure adequate serviceability, maximum capacity and peak operating efficiency. Actual clearances which appear inadequate should be reviewed with local Trane sales personnel.

Complete Coat™ Microchannel Condenser Coil

The cathodic epoxy type electrodisposition coating is formulated for high edge build to a number of different types of heat exchangers. The coating is selected to provide excellent resistance and durability to corrosive effects of alkalis, acids, alcohols, petroleum, seawater, salt air, and corrosive environments. This coating shall be available on microchannel condenser coils.

Condensate Trap

The evaporator is a draw-through configuration. A trap must be field provided prior to start-up on the cooling cycle.

Heating Operation

The heat exchanger is manufactured with aluminized steel.

To prevent condensation within the heat exchanger, do not exceed 50 percent outside air or a minimum mixed air temperature of 40°F.

Optional Stainless Steel Heat Exchanger

The optional stainless steel heat exchanger is manufactured with 409 stainless steel tubes and 439 stainless steel burners. To prevent corrosion and prolong heat exchanger reliability, the minimum mixed air temperature allowed across the heat exchanger is 40°F. Whenever high outside air or outside applications exist, this option should be utilized.

Low Ambient Cooling

The Foundation line features low ambient cooling down to 45°F. The following options need to be included/considered when low ambient applications are required: continuous fan operation, crankcase heaters, or low pressure bypass timer. Contact your local Trane Representative for more assistance with low ambient cooling applications.

Unit Pitch

These units have sloped condensate drain pans. Units must be installed level. Any unit slope must be toward access side of the unit.

Selection Procedure

Cooling Capacity

Note: Cooling capacity procedure is the same for cooling (E) and gas/electric (G).

1. Calculate the building's total and sensible cooling loads for the building at design conditions. Use the following calculation methods or any other standard accepted method.

Factors used in unit selection:

- Total Cooling Load: 180 MBh
- Sensible Cooling Load: 126 MBh
- Airflow: 6000 cfm
- Electrical Characteristics: 460/60/3
- Summer Design Conditions: Entering Evaporator Coil: 80°F DB/67°F WB
- Outdoor Ambient: 95°F
- External Static Pressure: 0.38 in. wg
- Rooftop – downflow configuration
- Efficiency: 14 SEER
- Accessories: Economizer, Roof Curb, Electric Heat

2. As a starting point, a rough determination must be made of the size of the unit. The final selection will be made after examining the performance at the given conditions. Divide the total cooling load by nominal Btuh per ton (12 MBh per ton); then round up to the nearest unit size.

$$180 \text{ MBh} / 12 \text{ MBh} = 15.0 \text{ tons}$$

3. [Table 10, p. 26](#) shows that a ECC180A4 has a gross cooling capacity of 187.2 MBh and 143 MBh sensible capacity at 6000 cfm and 95 DB outdoor ambient with 80 DB, 67 WB air entering the evaporator.

Find capacity at intermediate conditions not in the table

When the design conditions are between two numbers that are in the capacity table, interpolation is required to approximate the capacity.

Note: Extrapolation outside of the table conditions is not recommended.

4. In order to select the correct unit which meets the building's requirements, the fan motor heat must be deducted from the gross cooling capacity. The amount of heat that the fan motor generates is dependent on the effort by the motor - cfm and static pressure. To determine the total unit static pressure you add the external static pressure to the additional static related by the added features:

External Static Duct System	0.38 wg
Standard Filter 2 in. from Table 29, p. 41	0.05 wg
Economizer (100% Return Air) from Table 29, p. 41	0.04 wg
Electric Heater Size 36 kW from Table 29, p. 41	0.07 wg
Total Static Pressure	0.55 wg

Note: Reference heating capacity section on this page for determination of heater size. No additional static add for gas/heat exchanger.

Note: The Evaporator Fan Performance [Table 10, p. 26](#) has already accounted for the pressure drop for standard filters and wet coils (see note below in [Table 10, p. 26](#)). Therefore, the actual total static pressure is 0.55 - 0.05 (from) = 0.50 wg.

With 6000 cfm and 0.50 wg. [Table 10, p. 26](#) shows 1.37 bhp for this unit. Note below the table is the formula to calculate fan motor heat.

$$3.15 \times \text{bhp} = \text{MBh}$$

$$3.15 \times 1.37 = 4.32 \text{ MBh}$$

Now subtract the fan motor heat from the gross cooling capacity of the unit:

$$\text{Net Total Cooling Capacity} = 187.2 \text{ MBh} - 4.32 = 182.88 \text{ MBh.}$$

$$\text{Net Sensible Cooling Capacity} = 143 \text{ MBh} - 4.32 = 138.68 \text{ MBh.}$$

5. Compare your resulting capacities to the building load. If the performance will not meet the required load of the building's total or sensible cooling load, try a selection at the next higher size unit.

Heating Capacity

Note: Heating capacity procedures DIFFER for cooling (E) and gas/electric (G) units.

1. Calculate the building heating load.
2. Size the system heating capacity to match the calculated building heating load. The following are building heating requirements:

460 volt/3 phase Power Supply

Total heating load of 115.0 MBh

6000 cfm

The electric heat accessory capacities are listed in [Table 31, p. 42](#). From the table, a 36 kW heater will deliver 122.94 MBh at 480 volts. In order to determine capacity at 460 volts, the heater voltage correction factor from [Table 32, p. 43](#) must be used. Therefore, 122.94 MBh x 0.94 (voltage correction factor) = 115.6 MBh.

Gas/electric: Fuel natural gas total heating load of 195 MBh. [Table 30, p. 42](#) shows 250 MBh and 350 MBh input models. The output capacities of these furnaces are 203 MBh and 284 MBh respectively. The low heat model with 203 MBh output best matches the building requirements.

Air Delivery Selection

Note: Air Delivery procedures is the same for cooling (E) and gas/electric (G) units.

External static pressure drop through the air distribution system has been calculated to be 0.50 inches of water. From [Table 29, p. 41](#) static pressure drop through the economizer is 0.04 and the 36 kW heater is 0.07 inches of water (0.38 + 0.04 + 0.07). Enter for a ECC180A4 at 6000 cfm and 0.50 static pressure. The standard motor with the low static drive accessory at 622 rpm will give the desired airflow at a rated bhp of 1.37.

Model Number Description

Digit 1 — Unit Type

E = Packaged Cooling, Electric Heat
G = Packaged Gas/Electric

Digit 2 — Efficiency

C = Generation C

Digit 3 — Airflow Configuration

C = Convertible

Digit 4, 5, 6 — Nominal Gross Cooling Capacity (MBh)

180 = 15 Tons
210 = 17.5 Tons
240 = 20 Tons
300 = 25 Tons

Digit 7 — Major Design Sequence

A = Rev A

Digit 8 — Voltage Selection

3 = 208-230/60/3
4 = 460/60/3
W = 575/60/3

Digit 9 — Unit Controls

E = Electromechanical

Digit 10 — Heating Capacity

Note: Applicable to Digit 1 = E models only

0 = No Heat
G = 18 kW Electric Heat
N = 36 kW Electric Heat
P = 54 kW Electric Heat
R = 72 kW Electric Heat

Note: Applicable to Digit 1 = G models only

H = Gas Heat - High
L = Gas Heat - Low
M = Gas Heat - Medium
X = Gas Heat - SS Ht Ex - Low
Y = Gas Heat - SS Ht Ex - Medium
Z = Gas Heat - SS Ht Ex - High

Digit 11— Minor Design Sequence

Digit 12,13 — Service Sequence

00 = None

Digit 14 — Fresh Air Selection^{3, 4}

0 = No Fresh Air
A = Manual Outside Air Damper 0-25%
B = Motorized Outside Air Damper 0-50%
C = Economizer, Dry Bulb 0-100% without Barometric Relief
D = Economizer, Dry Bulb 0-100% with Barometric Relief¹
E = Economizer, Reference Enthalpy 0-100% without Barometric Relief
F = Economizer, Reference Enthalpy 0-100% with Barometric Relief¹
G = Economizer, Comparative Enthalpy 0-100% without Barometric Relief
H = Economizer, Comparative Enthalpy 0-100% with Barometric Relief¹
J = Downflow Low Leak Economizer, Dry Bulb w/o Barometric Relief
L = Downflow Low Leak Economizer, Reference Enthalpy w/o Barometric Relief
N = Downflow Low Leak Economizer, Comparative Enthalpy w/o Barometric Relief

Digit 15 — Supply Fan/Drive Type/Motor

7 = Multi-Speed Standard Motor
9 = Multi-Speed Oversized Motor

Digit 16 — Access

0 = Standard Fork Access
F = Third Side Condenser Fork Access (15-25 Ton)

Digit 17 — Condenser Coil Protection

0 = Standard Coil
4 = CompleteCoat™ Condenser Coil

Digit 18 — Through The Base Provisions

Note: Applicable to Digit 1, E models only

0 = No Through The Base Provisions
A = Through The Base Electric

Note: Applicable to Digit 1, G models only

0 = No Through The Base Provisions
A = Through The Base Electric
B = Through The Base Gas¹
C = Through The Base Electric/Gas

Digit 19 — Disconnect Switch

0 = No Disconnect
1 = Unit Mounted Non-Fused Disconnect Switch²

Digit 20-24

Not Used

Digit 25 — System Monitoring Controls

0 = No Monitoring Controls
A = Condensate Drain Pan Overflow Switch

Digit 26 — System Monitoring Controls

B = Economizer Fault Detection and Diagnostics (FDD)⁵

Model Number Notes

Notes:

1. Some field set up required.
2. Must be ordered with Through the- Base Electrical option.
3. All Factory Installed Options are Built-to-Order. Check order services for estimated production cycle.
4. Factory installed economizers only available in downflow configuration.
5. Fault Detection and Diagnostics (FDD) is available on Low Leak Economizers only.

General Data

Table 1. General data — 15 to 25 tons

	15 Ton	17.5 Ton	20 Ton	25 Ton	
	E/GCC180	E/GCC210	E/GCC240	ECC300	GCC300
Cooling Performance^(a)					
Gross Cooling Capacity	194,000	214,000	252,000	280,000	280,000
EER (Downflow/Horizontal)	11	11	10	10	9.8
Nominal Airflow CFM / AHRI Rated CFM	5400	6650	7000	8000	8000
AHRI Net Cooling Capacity	180,000	206,000	244,000	268,000	268,000
Integrated Energy Efficiency Ratio (IEER) (Multi Speed Fan)	14.2	14.2	13.2	13.2	13.2
Percent Capacity @ part load (Stage 1/Stage 2)	53 / 100	50 / 100	54 / 100	53 / 100	53 / 100
System Power (kW)	16.36	18.73	24.40	26.80	27.35
Compressor					
Number/Type	2 / Scrolls	2 / Scrolls	2 / Scrolls	2 / Scrolls	2 / Scrolls
Sound					
Outdoor Sound Rating (BELS)	9.5	9.5	9.5	9.5	9.5
Outdoor Coil					
Type	Microchannel	Microchannel	Microchannel	Microchannel	Microchannel
Coil Width (in.)	0.71	1.00	1.00	1.00	1.00
Face Area (sq. ft.)	34.74	34.74	34.74	34.74	34.74
Rows/FPI	1 / 23	1 / 21	1 / 23	1 / 23	1 / 23
Indoor Coil					
Type	Microchannel	Microchannel	Microchannel	Microchannel	Microchannel
Tube Size (in.) ID	1	1	1	1	1
Face Area (sq. ft.)	26.00	26.00	26.00	26.00	26.00
Rows/FPI	2/18	2/18	2/18	4/15	4/15
Refrigerant Control	TXV	TXV	TXV	TXV	TXV
Drain Connection Number/Size (in.)	1 / 1.00 PVC Pipe Female	1 / 1.00 PVC Pipe Female	1 / 1.00 PVC Pipe Female	1 / 1.00 PVC Pipe Female	1 / 1.00 PVC Pipe Female
Outdoor Fan					
Type	Propeller	Propeller	Propeller	Propeller	Propeller
Number Used/Diameter (in.)	2 / 28	2 / 28	2 / 28	2 / 28	2 / 28
Drive Type/No. Speeds	Direct / 1	Direct / 1	Direct / 1	Direct / 1	Direct / 1
cfm	15,900	15,900	15,900	15,900	15,900
Number Motors/hp	2 / 1.0	2 / 1.0	2 / 1.0	2 / 1.0	2 / 1.0
Motor rpm	1125	1125	1125	1125	1125
Indoor Fan					
Type	FC Centrifugal	FC Centrifugal	FC Centrifugal	FC Centrifugal	FC Centrifugal
Number Used/Diameter (in.)	2 / 15x15	2 / 15x15	2 / 15x15	2 / 15x15	2 / 15x15
Drive Type/No. Speeds	Belt / 1	Belt / 1	Belt / 1	Belt / 1	Belt / 1
Number Motors	1	1	1	1	1
Motor hp (Standard/Oversized)	3.0 / 5.0	5.0 / 7.5	5.0 / 7.5	7.5 / 10.0	7.5 / 10.0
Motor rpm (Standard/Oversized)	1750 / 3450	3450 / 3450	3450 / 3450	3450 / 1750	3450 / 1750
Motor Frame Size (Standard/Oversized)	145T / 145T	145T / 184T	145T / 184T	184T / 215T	184T / 215T
Filters					
Type Furnished ^(b)	Throwaway	Throwaway	Throwaway	Throwaway	Throwaway
Number Size Recommended	(8) 20x25x2	(8) 20x25x2	(8) 20x25x2	(8) 20x25x2	(8) 20x25x2
Refrigerant Charge (Pounds of R-410A)^(c)					
Circuit 1	14.6	15.2	16.5	17.8	17.8

^(a) Units are AHRI Certified to AHRI Standard 340-360 (I-P). Rating conditions are 95°F outdoor air temperature, 80°F entering dry bulb, 67°F entering wet bulb with minimum external static pressure as determined by rating standard.

^(b) Optional field-installed MERV 13 filters available.

^(c) Refrigerant charge is an approximate value. For a more precise value, see unit nameplate and service instructions.

General Data

Table 2. General data — heating performance – 15 to 25 tons

	Heating Performance					
	15 Tons			17.5 Tons ^(a)		
Heating Models	Low	Medium	High	Low	Medium	High ^(b)
Heating Input (Btu/h)	240,000	320,000	350,000	240,000	320,000	380,000 / 350,000
1 st Stage (Btu)	168,000	224,000	245,000	168,000	224,000	266,000 / 245,000
Heating Output (Btu/h)	194,400	259,200	283,500	194,400	259,200	307,800 / 283,500
1 st Stage (Btu)	136,080	181,440	198,450	136,080	181,440	215,460 / 198,450
Steady State Efficiency %	81	81	81	81	81	81 / 81
No. Burners	6	8	8	6	8	8 / 8
No. Stages	2	2	2	2	2	2 / 2
Gas Supply Line Pressure (in. wc)						
Natural Gas (minimum/maximum)	5.0/14.0	5.0/14.0	4.5/14.0	5.0/14.0	5.0/14.0	5.5/14.0 / 4.5/14.0
LP (minimum/maximum)	11.0/14.0	11.0/14.0	11.0/14.0	11.0/14.0	11.0/14.0	11.0/14.0 / 11.0/14.0
Gas Connection Pipe Size (in.)	3/4	3/4	3/4	3/4	3/4	3/4
	Heating Performance					
	20 to 25 Tons					
Heating Models	Low	Medium	High			
Heating Input (Btu/h)	240,000	320,000	380,000			
1 st Stage (Btu)	168,000	224,000	266,000			
Heating Output (Btu/h)	194,400	259,200	307,800			
1 st Stage (Btu)	136,080	181,440	215,460			
Steady State Efficiency %	81	81	81			
No. Burners	6	8	8			
No. Stages	2	2	2			
Gas Supply Line Pressure (in. wc)						
Natural Gas (minimum/maximum)	5.0/14.0	5.0/14.0	5.5/14.0			
LP (minimum/maximum)	11.0/14.0	11.0/14.0	11.0/14.0			
Gas Connection Pipe Size (in.)	3/4	3/4	3/4			

Note: Heating Performance limit settings and rating data were established and approved under laboratory test conditions using American National Standards Institute standards (ANSI). Ratings shown are for elevations up to 2000 feet. For elevations above 2000 feet, ratings should be reduced at the rate of 4% for each 1000 feet above sea level.

^(a) For 17.5T high heat option, input rate will de-rate from downflow to horizontal.
^(b) Downflow / Horizontal

Table 25. Standard motor and drive/fan speed (rpm)

Tons	Unit Model Number	6 Turns Open	5 Turns Open	4 Turns Open	3 Turns Open	2 Turns Open	1 Turn Open	Closed
15	E/G*C180A3,4,W	653	669	746	793	839	886	N/A
17.5	E/G*C210A3,4,W	721	772	824	875	927	978	N/A
20	G*C240A3,4,W	824	875	927	978	1030	1081	N/A
	E*C240A3,4,W	721	772	824	875	927	978	N/A
25	G*C300A3,4,W	995	1048	1100	1153	1205	1257	N/A
	E*C300A3,4,W	886	912	957	1003	1048	1094	N/A

Note: Factory set at 3 turns open.

Table 26. Standard motor and low static drive accessory sheave/fan speed (rpm)

Tons	Unit Model Number	6 Turns Open	5 Turns Open	4 Turns Open	3 Turns Open	2 Turns Open	1 Turn Open	Closed
15	E/G*C180A3,4,W	488	523	558	592	627	662	N/A
17.5	E/G*C210A3,4,W	560	596	632	668	703	739	N/A
20	G*C240A3,4,W	627	672	717	762	806	851	N/A
	E*C240A3,4,W	538	574	609	645	681	717	N/A
25	G*C300A3,4,W	838	891	943	995	1048	1100	N/A
	E*C300A3,4,W	729	775	821	866	912	957	N/A

Table 27. Standard motor and high static drive accessory sheave/fan speed (rpm)

Tons	Unit Model Number	6 Turns Open	5 Turns Open	4 Turns Open	3 Turns Open	2 Turns Open	1 Turn Open	Closed
15	E/G*C180A3,4,W	886	932	979	1026	1072	1119	N/A
17.5	E/G*C210A3,4,W	978	1030	1081	1133	1184	1236	N/A
20	E/G*C240A3,4,W	863	918	974	1029	1085	1141	N/A
25	E*C300A3,4,W	995	1048	1100	1153	1205	1257	N/A

Table 28. Oversized motor and drive/fan speed (rpm)

Tons	Unit Model Number	6 Turns Open	5 Turns Open	4 Turns Open	3 Turns Open	2 Turns Open	1 Turn Open	Closed
15	E/G*C180A3,4,W	847	908	968	1029	1089	1150	N/A
17.5	E/G*C210A3,4,W	995	1048	1100	1153	1205	1257	N/A
20	E/G*C240A3,4,W	995	1048	1100	1153	1205	1257	N/A
25	E/G*C300A3,4,W	1108	1151	1194	1237	1280	1323	N/A

Table 29. Static pressure drop through accessories (inches water column)

Tons	Unit Model Number	cfm	2 in. Standard Filters	2-in. MERV 13 Filters	Standard Economizer with OA/RA Dampers ^(a)		Low Leak Economizer with OA/RA Dampers ^(a)		Electric Heater Accessory (kW) ^(b)			
					100% OA	100% RA	100% OA	100% RA	18	36	54	72
					15	E/G*C180A (Downflow)	4800	0.03	0.10	0.15	0.04	0.19
6000	0.05	0.14	0.20	0.04			0.31	0.34	0.02	0.02	—	—
7200	0.07	0.17	0.27	0.04			0.45	0.48	0.03	0.03	—	—
E/G*C180A (Horizontal)	4800	0.03	0.1	0.15		0.04	0.19	0.22	0.01	0.01	—	—
	6000	0.05	0.14	0.2		0.04	0.31	0.34	0.02	0.02	—	—
	7200	0.07	0.17	0.27		0.04	0.45	0.48	0.04	0.04	—	—
17.5	E/G*C210A (Downflow)	5600	0.05	0.12	0.18	0.04	0.27	0.29	—	0.03	0.04	0.04
		7000	0.07	0.16	0.26	0.04	0.42	0.46	—	0.05	0.05	0.06
		8400	0.10	0.20	0.35	0.06	0.61	0.66	—	0.06	0.07	0.09
	E/G*C210A (Horizontal)	5600	0.05	0.12	0.18	0.04	0.27	0.29	—	0.03	0.04	0.04
		7000	0.07	0.16	0.26	0.04	0.42	0.46	—	0.05	0.06	0.07
		8400	0.10	0.20	0.35	0.06	0.61	0.66	—	0.07	0.09	0.11

Performance Data

Table 29. Static pressure drop through accessories (inches water column) (continued)

Tons	Unit Model Number	cfm	2 in. Standard Filters	2-in. MERV 13 Filters	Standard Economizer with OA/RA Dampers ^(a)		Low Leak Economizer with OA/RA Dampers ^(a)		Electric Heater Accessory (kW) ^(b)			
					100% OA	100% RA	100% OA	100% RA	18	36	54	72
20	E/G*C240A (Downflow)	6400	0.07	0.15	0.22	0.04	0.35	0.38	—	0.04	0.05	0.05
		8000	0.10	0.19	0.32	0.05	0.55	0.60	—	0.05	0.07	0.08
		9600	0.17	0.24	0.44	0.07	0.81	0.86	—	0.06	0.08	0.11
	E/G*C240A (Horizontal)	6400	0.07	0.15	0.22	0.04	0.35	0.38	—	0.04	0.05	0.06
		8000	0.10	0.19	0.32	0.05	0.55	0.60	—	0.07	0.08	0.10
		9600	0.17	0.24	0.44	0.07	0.81	0.86	—	0.09	0.11	0.14
25	E/G*C300A (Downflow)	7000	0.07	0.16	0.26	0.04	0.42	0.46	—	0.05	0.05	0.06
		9000	0.10	0.22	0.40	0.07	0.71	0.75	—	0.06	0.08	0.10
		11000	0.17	0.28	0.57	0.10	1.07	1.12	—	0.07	0.10	0.12
	E/G*C300A (Horizontal)	7000	0.07	0.16	0.26	0.04	0.42	0.46	—	0.05	0.06	0.07
		9000	0.10	0.22	0.40	0.07	0.71	0.75	—	0.08	0.10	0.12
		11000	0.17	0.28	0.57	0.10	1.07	1.12	—	0.13	0.18	0.23

^(a) OA = Outside Air and RA = Return Air.

^(b) Nominal kW ratings at 240, 480, 600 volts.

Table 30. Gas fired heating capacities

Tons	Unit Model Number	Heating Input (MBh) ^(a)	Heating Output (MBh) ^(a)	Air Temp Rise (°F)
15	G*C180A(3,4,W)E(L or X)	240/168	194/136	15-45
	G*C180A(3,4,W)E(M or Y)	320/224	259/181	20-50
	G*C180A(3,4,W)E(H or Z)	350/245	284/198	25-55
17.5 ^(b)	G*C210A(3,4,W)E(L or X)	240/168	194/136	15-45
	G*C210A(3,4,W)E(M or Y)	320/224	259/181	20-50
	G*C210A(3,4,W)E(H or Z)- Downflow	380/266	308/215	20-50
	G*C210A(3,4,W)E(H or Z)- Horizontal	350/245	284/198	25-55
20	G*C240A(3,4,W)E(L or X)	240/168	194/136	15-45
	G*C240A(3,4,W)E(M or Y)	320/224	259/181	20-50
	G*C240A(3,4,W)E(H or Z)	380/266	308/215	20-50
25	G*C300A(3,4,W)E(L or X)	240/168	194/136	15-45
	G*C300A(3,4,W)E(M or Y)	320/224	259/181	20-50
	G*C300A(3,4,W)E(H or Z)	380/266	308/215	20-50

^(a) For two stage heaters (input or output), second stage is total heating capacity. Second stage/first stage.

^(b) For 17.5T high heat option, input rate will de-rate from downflow to horizontal.

Table 31. Auxiliary electric heat capacity

Tons	Unit Model Number	Total ^(a)		No. of Stages	Stage1		Stage 2	
		kW Input ^(b)	MBh Output		kW Input	MBh Output	kW Input	MBh Output
15	E*C180A3,4,W	18	61.5	1	18	61.5	—	—
		36	122.9	2	18	61.5	18	61.5
		54	184.4	2	36	122.9	18	61.5
17.5 - 25	E*C210A3,4,W E*C240A3,4,W E*C300A3,4,W	36	122.9	2	18	61.5	18	61.5
		54	184.4	2	36	122.9	18	61.5
		72	245.9	2	36	122.9	36	122.9

^(a) Heaters are rated at 240V, 480V, and 600V. For other than rated voltage, CAP = (voltage/rated voltage) x rated cap.

^(b) For all input/output categories, does not include fan power or heat.

Table 32. Electric heater voltage correction factors (applicable to auxiliary heat capacity)

Nominal Voltage	Distribution Voltage	Capacity Multiplier
240	208	0.75
	230	0.92
	240	1.00
480	380	0.63
	440	0.84
	460	0.94
	480	1.00
600	540	0.81
	575	0.92
	600	1.00

Table 33. Air temperature rise across electric heaters (°F)

kW	Stages	15 Tons 6000 cfm E*C180A	17.5 Tons 7000 cfm E*C210A	20 Tons 8000 cfm E*C240A	25 Tons 9000 cfm E*C300A
18	1	9.5	—	—	—
36	2	19.0	16.3	14.2	12.6
54	2	28.5	24.4	21.3	19
72	2	—	32.5	28.5	25.3

Notes:

1. For minimum design airflow, see airflow performance table for each unit.
2. To calculate temp rise at different airflow, use the following formula: Temp. rise across Electric Heater = kW x 3414/1.08 x cfm.

Electrical Data

Table 34. Unit wiring with cooling (no electric heat) or gas heat

TONS	Unit Model Number	Unit Operating Voltage Range	Standard Indoor Fan Motor		Oversized Indoor Fan Motor	
			Minimum Circuit Ampacity ^(a)	Maximum Fuse Size or Maximum Circuit Breaker	Minimum Circuit Ampacity	Maximum Fuse Size or Maximum Circuit Breaker
15	E/GCC180A3	208-230	79	100	85	110
	E/GCC180A4	460	36	45	39	50
	E/GCC180AW	575	30	35	32	40
17.5	E/GCC210A3	208-230	92	110	99	125
	E/GCC210A4	460	40	50	44	50
	E/GCC210AW	575	33	40	36	45
20	E/GCC240A3	208-230	101	125	109	125
	E/GCC240A4	460	50	60	53	60
	E/GCC240AW	575	39	50	42	50
25	E/GCC300A3	208-230	133	175	140	175
	E/GCC300A4	460	58	70	61	70
	E/GCC300AW	575	46	60	48	60

^(a) For Standard and Oversized Indoor Fan Motor, values do not include power exhaust accessory.

Table 35. Unit wiring with electric heat (single point connection)

Tons	Unit Model Number	Heater Model Number	Heater kW Rating	Control Stages	Standard Indoor Motor		Oversized Indoor Motor	
					MCA	Max Fuse Size or Max Circuit Breaker	MCA	Max Fuse Size or Max Circuit Breaker ^(a)
208/230 Volts Three Phase								
15	ECC180A3	BAYHTFB318A	13.5/18	1	79	100	85	110
		BAYHTFC336A	27/36	2	108/122	110/125	115/130	125/150
		BAYHTFC354A	40.5/54	2	155/144	175	162/151	175
17.5	ECC210A3	BAYHTFC336A	27/36	2	115/130	125/150	125/139	125/150
		BAYHTFC354A	40.5/54	2	162/151	175	172/161	175
		BAYHTFC372A	54/72	2	172/195	200/225	181/204	200/225
20	ECC240A3	BAYHTFD336A	27/36	2	115/130	125/150	125/139	125/150
		BAYHTFD354A	40.5/54	2	162/151	175	172/161	175
		BAYHTFD372A	54/72	2	172/195	200/225	181/204	200/225
25	ECC300A3	BAYHTFD336A	27/36	2	133/139	175	140/147	175
		BAYHTFD354A	40.5/54	2	172/161	175	180/169	200/175
		BAYHTFD372A	54/72	2	181/204	200/225	189/212	200/225
460 Volts Three Phase								
15	ECC180A4	BAYHTFB418A	18	1	36	45	39	50
		BAYHTFC436A	36	2	61	70	64	70
		BAYHTFC454A	54	2	72	90	75	90
17.5	ECC210A4	BAYHTFC436A	36	2	64	70	68	70
		BAYHTFC454A	54	2	75	90	79	90
		BAYHTFC472A	72	2	97	110	101	110
20	ECC240F4	BAYHTFD436A	36	2	64	70	68	70
		BAYHTFD454A	54	2	75	90	79	90
		BAYHTFD472A	72	2	97	110	101	110
25	ECC300A4	BAYHTFD436A	36	2	68	70	72	80
		BAYHTFD454A	54	2	79	90	83	90
		BAYHTFD472A	72	2	101	110	105	110
575 Volts Three Phase								
15	ECC180AW	BAYHTFBW18A	18	1	30	35	32	40
		BAYHTFCW36A	36	2	49	50	51	60
		BAYHTFCW54A	54	2	57	70	60	70
17.5	ECC210AW	BAYHTFCW36A	36	2	51	60	55	60
		BAYHTFCW54A	54	2	60	70	64	70
		BAYHTFCW72A	72	2	77	90	81	90
20	ECC240AW	BAYHTFDW36A	36	2	51	60	55	60
		BAYHTFDW54A	54	2	60	70	64	70
		BAYHTFDW72A	72	2	77	90	81	90
25	ECC300AW	BAYHTFDW36A	36	2	55	60	58	60
		BAYHTFDW54A	54	2	64	70	66	70
		BAYHTFDW72A	72	2	81	90	84	90

^(a) Values do not include power exhaust accessory.

Electrical Data

Table 36. Electrical characteristics—compressor motor and condenser motor

Tons	Unit Model No.	Compressor Motors						Condenser Fan Motors				
		No.	Volts	Phase	rpm	Amps ^(a)		No.	Phase	hp	Amps	
						RLA	LRA				FLA	LRA
15	E/GCC180A3	2	280–230	3	3500	26.9/24.9	208/180	2	3	1	4.8	20.0
	E/GCC180A4	2	460	3	3500	12.1/10.8	98/75	2	3	1	2.5	10.1
	E/GCC180AW	2	575	3	3500	10.1/8.8	75/60	2	3	1	1.9	8.0
17.5	E/GCC210A3	2	280–230	3	3500	28.9/28.9	208/208	2	3	1	4.8	20.0
	E/GCC210A4	2	460	3	3500	12.1/12.1	98/98	2	3	1	2.5	10.1
	E/GCC210AW	2	575	3	3500	10.1/10.1	75/75	2	3	1	1.9	8.0
20	E/GCC240A3	2	280–230	3	3500	35.7/29.6	240/240	2	3	1	4.8	20.0
	E/GCC240A4	2	460	3	3500	16.8/15.5	140/130	2	3	1	2.5	10.1
	E/GCC240AW	2	575	3	3500	13.6/11.8	107.6/93.7	2	3	1	1.9	8.0
25	E/GCC300A3	2	280–230	3	3500	50.5/35.7	245/240	2	3	1	4.8	20.0
	E/GCC300A4	2	460	3	3500	19.5/16.8	125/140	2	3	1	2.5	10.1
	E/GCC300AW	2	575	3	3500	15.5/13.6	100/107.6	2	3	1	1.9	8.0

^(a) For Compressor Motors and Condenser Fan Motors: Amp draw for each motor; multiply value by number of motors to determine total amps.

Table 37. Electrical characteristics—evaporator fan motor

Tons	Unit Model Number	Standard Evaporator Fan Motor						Oversized Evaporator Fan Motor					
		No.	Volts	Phase	hp	Amps		No.	Volts	Phase	hp	Amps	
						FLA	LRA					FLA	LRA
15	E/GCC180A3	1	208–230	3	3	10.6	83.0	1	208–230	3	5	16.7	110.0
	E/GCC180A4	1	460	3	3	4.8	35.5	1	460	3	5	7.6	56.0
	E/GCC180AW	1	575	3	3	3.9	31.0	1	575	3	5	6.1	44.0
17.5	E/GCC210A3	1	208–230	3	5	16.7	110.0	1	208–230	3	7.5	24.2	150.0
	E/GCC210A4	1	460	3	5	7.6	56.0	1	460	3	7.5	11.0	75.0
	E/GCC210AW	1	575	3	5	6.1	44.0	1	575	3	7.5	9.0	60.0
20	E/GCC240A3	1	208–230	3	5	16.7	110.0	1	208–230	3	7.5	24.2	150.0
	E/GCC240A4	1	460	3	5	7.6	56.0	1	460	3	7.5	11.0	75.0
	E/GCC240AW	1	575	3	5	6.1	44.0	1	575	3	7.5	9.0	60.0
25	E/GCC300A3	1	208–230	3	7.5	24.2	150.0	1	208–230	3	10	30.8	227.2
	E/GCC300A4	1	460	3	7.5	11.0	75.0	1	460	3	10	14.0	113.6
	E/GBC300AW	1	575	3	7.5	9.0	60.0	1	575	3	10	11.0	90.8

Table 38. Electrical characteristics—combustion blower motor (gas heat units)

Unit Model Number	Heat	Heating Stages	hp	rpm ^(a)	Volts	Phase	Amps	
							FLA	LRA
GCC180A,210A,240A,300A	Low	2	1/15	3350/2800	208–230	1	0.36	0.72
GCC180A,210A,240A,300A	Med/High	2	1/6	3300/2300	208–230	1	0.95	1.41

^(a) High/Low Speed.

Table 39. Electrical characteristics—power exhaust

Tons	Volts	Phase	Hp	rpm	Amps	
					FLA	LRA
15-25	280-230	1	3/4	1040	6.6	13.5
	460	1	3/4	1040	3.2	8.4
	575	1	3/4	1040	2.1	5.2

Dimensional Data

Figure 1. Cooling with optional electrical heat — overview (gas/electric)

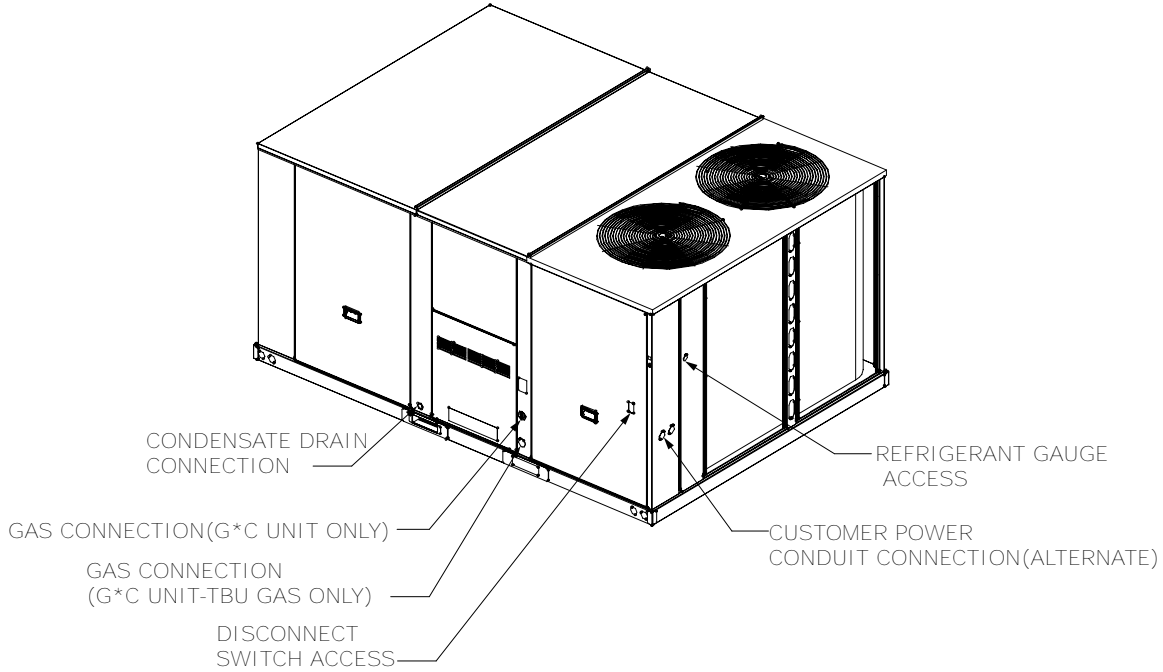
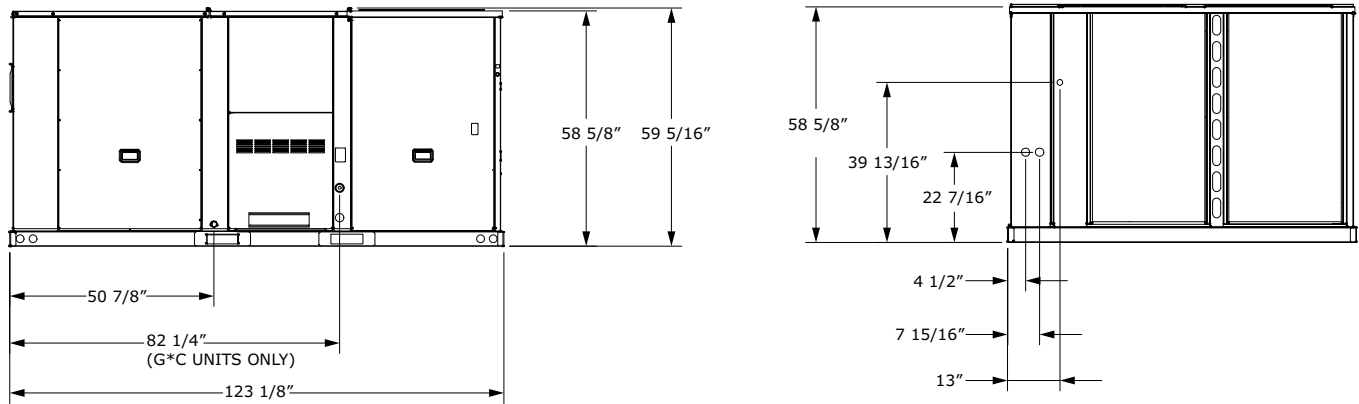

Figure 2. Cooling with optional electrical heat — front and side views (gas/electric)



NOTES:

1. THROUGH THE BASE GAS AND ELECTRICAL IS NOT STANDARD ON ALL UNITS.
2. VERIFY WEIGHT, CONNECTION, AND ALL DIMENSIONS WITH INSTALLER DOCUMENTS BEFORE INSTALLATION.

Weights

Table 41. Maximum unit and corner weights (lb) and center of gravity dimensions (in.) cooling with optional electric heat units only

Tons	Unit Model No.	Weights (lb) ^{(a), (b)}		Corner Weights ^(c)				Center of Gravity (in.)	
		Shipping	Net	A	B	C	D	Length	Width
15	ECC180A	2175	1850	638	477	367	367	56	35
17.5	ECC210A	2180	1855	637	479	369	369	56	35
20	ECC240A	2185	1860	632	484	372	372	55	37
25	ECC300A	2221	1896	644	492	379	379	55	36

(a) Weights are approximate. Horizontal and downflow unit and corner weights may vary slightly.
 (b) Weights do not include additional factory or field installed options/accessories.
 (c) Corner weights are given for information only. 15–25 ton models must be supported continuously by a curb or equivalent frame support.

Table 42. Maximum unit and corner weights (lb) and center of gravity dimensions (in.) gas/electric heat units only

Tons	Unit Model No.	Weights (lb) ^{(a), (b)}		Corner Weights ^(c)				Center of Gravity (in.)	
		Shipping	Net	A	B	C	D	Length	Width
15	GCC180A	2339	2013	649	508	398	459	55	37
17.5	GCC210A	2353	2028	653	511	399	464	55	37
20	GCC240A	2350	2025	643	512	403	466	55	37
25	GCC300A	2386	2061	671	524	393	472	55	36

(a) Weights are approximate. Horizontal and downflow unit and corner weights may vary slightly.
 (b) Weights do not include additional factory or field installed options/accessories.
 (c) Corner weights are given for information only. 15 to 25 ton models must be supported continuously by a curb or equivalent frame support.

Figure 10. Corner weights

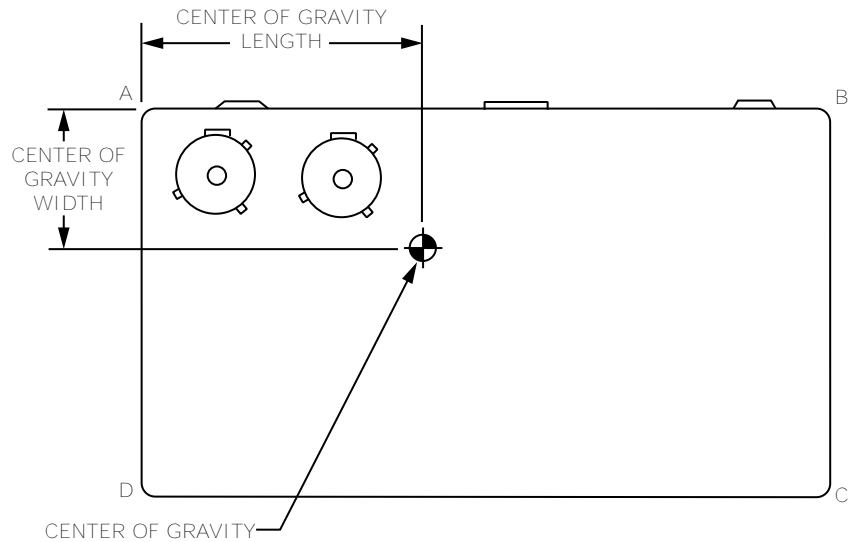

Note: To calculate additional weight for accessories, see Accessory net weights table.

Mechanical Specifications

General

- Packaged rooftop units cooling, heating capacities, and efficiencies are AHRI Certified within scope of AHRI Standard 340-360 (I-P) and ANSIZ21.47 and 10 CFR Part 431 pertaining to Commercial Warm Air Furnaces
- Packaged rooftop units are dedicated downflow or horizontal airflow
- Operating range between 125°F and 40°F in cooling standard from the factory
- Factory assembled, internally wired, fully charged with R-410A, and 100 percent run tested to check cooling operation, fan and blower rotation, and control sequence before leaving the factory
- Colored and numbered wiring internal to the unit for simplified identification
- Units ETL listed and labeled, classified in accordance UL 1995/C 22.2, 236-15 5th Edition

Standard Features

Casing

- Zinc coated, heavy gauge, galvanized steel
- Weather-resistant baked enamel finish on phosphatized exterior surfaces
- Meets ASTM B117, 672 hour salt spray test
- Removable single side maintenance access panels
- Lifting handles in maintenance access panels (can be removed and reinstalled by removing no more than three fasteners while providing a water and air tight seal)
- Exposed vertical panels and top covers in the indoor air section shall be insulated with a 1/2-inch, 1-pound density foil-faced, fire-resistant, permanent, odorless, glass fiber material
- Base of unit shall be insulated with 1/2-inch, 1-pound density, foil-faced, glass fiber material
- Base pan shall have no penetrations within the perimeter of the curb other than the raised 1 1/8-inch high downflow supply/return openings to provide an added water integrity precaution, if the condensate drain backs up
- Downflow unit's base pan shall have no penetrations within the perimeter of the curb other than the raised 1 1/8-inch high supply/return openings to provide an added water integrity precaution, if the condensate drain backs up
- Base of unit shall have provisions for forklift and crane lifting

Compressors

- All units have direct-drive, hermetic, scroll type compressors with centrifugal type oil pumps
- Suction gas-cooled motor with voltage utilization range of plus or minus 10 percent of unit nameplate voltage
- Internal overloads standard with scroll compressors
- All models have phase monitors and Low and High Pressure Controls as standard

Controls

- Units factory-wired with necessary controls and contactor pressure lugs or terminal block for power wiring
- External location available for mounting a fused disconnect device

Crankcase Heaters

- Offered as standard on 15 and 20 Ton
- Offered as field installed option on 25 Ton
- Band heaters provide improved compressor reliability by warming the oil to prevent migration during off-cycles or low ambient conditions.

Mechanical Specifications

Discharge Line Thermostat

- A bi-metal element discharge line thermostat is installed as a standard option on the discharge line of each system
- Provides extra protection to the compressors against high discharge temperatures in case of loss of charge, extremely high ambient and other conditions which could drive the discharge temperature higher
- Wired in series with high pressure control
- When discharge temperature rises above the protection limit, the bi-metal disc in the thermostat switches to the off position, opening the 24 Vac circuit
- When temperature on the discharge line cools down, the bi-metal disc closes the contactor circuit, providing power to the compressor

Evaporator and Condenser Coils

- Microchannel coils burst tested by manufacturer
- Microchannel condenser coils standard on all units
- Coils leak tested to ensure the pressure integrity
- Evaporator coil and condenser coil leak tested to 225 psig and pressure tested to 450 psig
- Sloped condensate drain pans are standard

Filters

Two inch standard filters shall be factory supplied on all units.

Gas Heat Section

- Progressive tubular heat exchanger, stainless steel burners and corrosion resistant steel
- Induced draft combustion blower shall be used to pull the combustion products through the firing tubes
- Heater shall use a direct spark ignition (DSI) system
- On initial call for heat, the combustion blower shall purge the heat exchanger for 20 seconds before ignition
- After three unsuccessful ignition attempts, entire heating system shall be locked out until manually reset at the thermostat/zone sensor
- Units shall be suitable for use with natural gas or propane (field-installed kit)
- Units shall comply with the California requirement for low NOx emissions (gas heat only)

Indoor Fan

- Belt driven, FC centrifugal fans with adjustable motor sheaves
- Motors thermally protected
- Oversized motors available for high static application
- Indoor fan motors meet the U.S. Energy Policy Act of 1992 (EPACT)

Locking Safety Device

- Pressure switch monitoring allows for lockout in a situation where the switch is opened
- By monitoring the Y input as well as the pressure switches, advanced decision making can be made to identify situations where faults/errors occur

Outdoor Fans

- Outdoor fan shall be direct-drive, statically and dynamically balanced, draw-through in the vertical discharge position
- Fan motor(s) shall be permanently lubricated and shall have built-in thermal overload protection

Phase Monitor

- 3-phase line monitor module

- Protects against phase loss, phase imbalance and phase reversal indication
- Intended to protect compressors from reverse rotation
- Operating input voltage range of 180–600 Vac
- LED indicators for ON and FAULT
- No field adjustments
- Module will automatically reset from a fault condition

Refrigerant Circuits

- Each refrigerant circuit shall have a fixed orifice, service pressure ports, and refrigerant line filter driers factory installed as standard
- An area shall be provided for replacement suction line driers

Refrigerant Pressure Control

All units include High and Low Pressure Cutouts as standard.

Unit Top

The top cover shall be double hemmed and gasket sealed to prevent water leakage.

Factory Installed Options

Complete Coat™ Microchannel Condenser Coil

- Cathodic epoxy type electro-disposition coating formulated for high edge build to a number of different types of heat exchangers
- Coating provides excellent resistance and durability to corrosive effects of alkalis, acids, alcohols, petroleum, seawater, salt air and corrosive environments
- Option is available on the microchannel type condenser coil

Multi-Speed Indoor Fan System

- Designed for use in applications for meeting the minimum requirement of CA Title 24
- Incorporates a multi-speed fan control to change the speed of the fan to 67% of full airflow based off of compressor stages

Stainless Steel Heat Exchanger

- Gas heat exchanger shall be of tubular heat exchanger design
- Constructed from a minimum 409 grade stainless steel tubes and 439 stainless steel burners
- Shall have a 10-year warranty as standard (Gas/Electric only)

Third Side Fork Access

This option shall provide fork openings on condenser end of unit for ease of maneuvering unit through narrow openings.

Factory or Field Installed Options

Barometric Relief

- Designed to be used on downflow units
- Barometric relief is an unpowered means of relieving excess building pressure

Condensate Overflow Switch

This option shall shut the unit down in the event that a clogged condensate drain line prevents proper condensate removal from the unit.

Mechanical Specifications

Economizer (Standard) — Downflow

- Assembly includes fully modulating 0–100% motor and dampers, barometric relief, minimum position setting, preset linkage, wiring harness with plug, fixed dry bulb and spring return actuator
- Barometric relief damper shall provide a pressure operated damper that shall be gravity closing and shall prohibit entrance of outside air during the equipment “off” cycle

Electric Heaters

- Electric heat modules shall be available for installation within the basic unit
- Elements shall be constructed of heavy-duty nickel chromium elements internally delta connected for 240 volt, wye connected for 480 and 600 volt
- Each heater package shall have temperature high limiting devices that are equipped with an auto-resetting and a single operation switch operating as line break limits
- Single operation switch shall act as a backup limit control if the auto resetting switch fail to operate appropriately
- All heaters shall be individually fused from the factory, where required, and shall meet all NEC and CEC requirements when properly installed
- Power assemblies shall provide single-point connection
- Electric heat modules shall be UL listed or CSA certified
- If ordering the Through the Base Electrical option with an Electric Heater, the heater must be factory installed.

Low Leak Economizer with Fault Detection & Diagnostics - Downflow

- Economizer meets the damper leakage requirements for ASHRAE 90.1, IECC, and California Title 24 standards (3 cfm/ft² at 1.0 in. w.g. for outside air dampers and 4 cfm/ft² for return dampers).
- Controller shall have the capability to provide the value of each sensor used in controlling the economizer operation
- System status is also indicated for the following conditions:
 - Free cooling available
 - Economizer enabled
 - Compressor enabled
 - Heating Enabled
 - Mixed air low limit cycle active
- Fault Detection and Diagnostic system detects the following faults:
 - Air temperature sensor failure/fault
 - Not economizing when conditions indicate system should be economizing
 - Economizing when conditions indicate system should not be economizing
 - Dampers are not modulating
 - Excessive amounts of outside air are being introduced through the economizer
- Fault Detection and Diagnostic system is certified by the California Energy Commission as meeting requirements of California Title 24 120.2(i)1 through 120.2(i)8 in accordance with Section 100(h)

Manual Outside Air Damper

The rain hood and screen shall provide up to 25% outside air.

Motorized Outside Air Damper

- Manually set outdoor air dampers shall provide up to 50% outside air
- Outdoor air dampers shall open to set position when indoor fan starts
- Damper shall close to the full closed position when indoor fan shuts down

Oversized Motors

Oversized motors shall be available for high static applications.

Note: 10 hp oversized motor is factory installed only.

Reference or Comparative Enthalpy

- Used to measure and communicate outdoor humidity
- Unit receives and uses this information to provide improved comfort cooling while using the economizer
- Comparative Enthalpy measures and communicates humidity for both outdoor and return air conditions, and return air temperature – unit receives and uses this information to maximize use of economizer cooling, and to provide maximum occupant comfort control
- Reference or Comparative Enthalpy option shall be available when a factory or field installed Downflow Economizer is ordered
- Option is available on all models

Through the Base Electrical with Disconnect Switch

- Three-pole, molded case, disconnect switch with provisions for through the base electrical connections are available
- Installed in the unit in a water tight enclosure with access through a swinging door
- Factory wiring shall be provided from the switch to the unit high voltage terminal block
- Switch shall be UL/CSA agency recognized

Note: The disconnect switch will be sized per NEC and UL guidelines but will not be used in place of unit overcurrent protection.

Through the Base Gas Piping

- Unit shall include a standard through the base gas provision
- Option shall have all piping necessary including, black steel, manual gas shut-off valve, elbows, and union
- Manual shutoff valve shall include a 1/8" NPT pressure tap
- Assembly will require minor field labor to install (Gas/Electric Only)

Through the Base Utilities Access

- Electrical service entrance shall be provided allowing electrical access for both control and main power connections inside the curb and through the base of the unit
- Option shall allow for field installation of liquid-tight conduit and an external field installed disconnect switch

Field Installed Options

Crankcase Heaters

- Offered as standard on 15 and 20 Ton
- Offered as field installed option on 25 Ton
- Band heaters provide improved compressor reliability by warming the oil to prevent migration during off-cycles or low ambient conditions.

Demand Control Ventilation with CO₂ Sensor

- CO₂ sensor shall have the ability to monitor the concentration (parts per million, ppm) of CO₂ (Carbon Dioxide) in the air
- As the CO₂ concentration changes, the outside air damper modulates to meet the current ventilation needs of the zone

Mechanical Specifications

Economizer – Horizontal

The horizontal economizer shall contain the same features as the downflow economizer with the exception of barometric relief.

Filters

Two inch standard filters shall be factory supplied on all units.

Hail Guards

Tool-less, hail protection quality coil guards are available for condenser coil protection.

Low and High Static Drive

The high static drive option shall allow the standard motor on all units to operate at various external static pressure conditions.

Low Leak Economizer with Fault Detection & Diagnostics - Downflow

- Economizer meets the damper leakage requirements for ASHRAE 90.1, IECC, and California Title 24 standards (3 cfm/ft² at 1.0 in. w.g. for outside air dampers and 4 cfm/ft² for return dampers).
- Controller shall have the capability to provide the value of each sensor used in controlling the economizer operation
- System status is also indicated for the following conditions:
 - Free cooling available
 - Economizer enabled
 - Compressor enabled
 - Heating Enabled
 - Mixed air low limit cycle active
- Fault Detection and Diagnostic system detects the following faults:
 - Air temperature sensor failure/fault
 - Not economizing when conditions indicate system should be economizing
 - Economizing when conditions indicate system should not be economizing
 - Dampers are not modulating
 - Excessive amounts of outside air are being introduced through the economizer
- Fault Detection and Diagnostic system is certified by the California Energy Commission as meeting requirements of California Title 24 120.2(i)1 through 120.2(i)8 in accordance with Section 100(h)

Powered Exhaust

The powered exhaust shall provide exhaust of return air, when using an economizer, to maintain better building pressurization.

Remote Potentiometer

The minimum position setting of the economizer shall be adjusted with this accessory.

Roof Curb – Downflow

- Roof curb shall be designed to mate with the downflow unit and provide support and a water tight installation when installed properly
- Design shall allow field-fabricated rectangular supply/return ductwork to be connected directly to the curb
- Curb shall be shipped knocked down for field assembly and shall include wood nailer strips