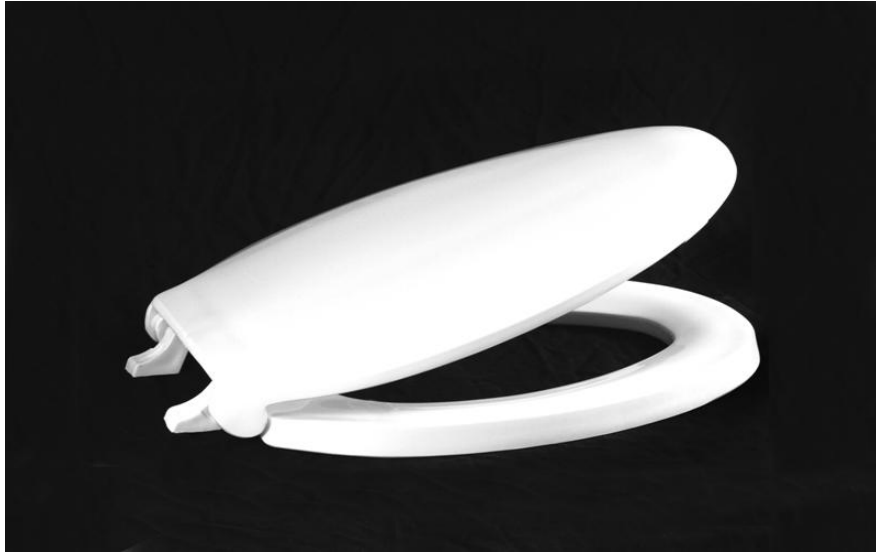

COMMERCIAL HEAVY DUTY

Product Specifications

Shape	Elongated
Seat Material	Polypropylene
Seat Form	Closed front
Commercial Hinge	Yes
Bolt Material	Stainless steel
Hardware Material	Stainless Steel
Check Hinge	Yes
Cover	Yes
Custom Gasket	Yes
Color	White

Warranty 1 year limited warranty

Available Colors

White, bone, crane white, black,

Features
Commercial Hinge

Includes commercial grade hinges. One piece solid metal hinge pin and bolt over molded with plastic.

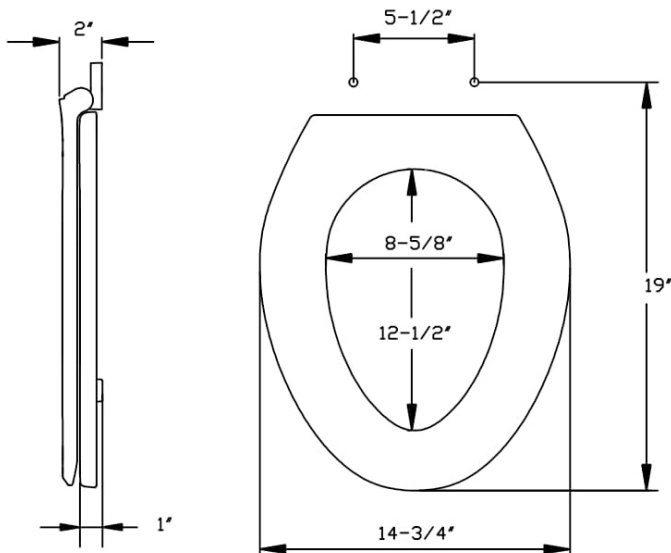

Dimensions shown are nominal and may vary within a range of tolerance. Product specifications are subject to change without notice.